



MF 4 mini oven

*Instruction
manual*



**This product ,
is produced in modern facilities which
are respectful to environment,without
giving harm to the nature**

Dear Customer,

It is our ultimate desire that you achieve the best performance from our product, which has been passed through meticulous quality control checks and is manufactured in modern facilities.

To this effect, we recommend that you read the entire guide carefully before operating the product and keep it as a reference.



This product has 10 years life span.

It means that said period is time interval to stock its spare parts to keep this product functional.



Contents

1	Technical specifications	Page 2
----------	---------------------------------	---------------

2	Safety precaution and important items	Page 3
----------	--	---------------

3	Using of the cooker	Page 5
----------	----------------------------	---------------

Introducing the control panel.....	5
Using of the cooker	6
Transport	11

4	Maintenance and cleaning	Page 9
----------	---------------------------------	---------------

1 Technical specification

External dimensions

Width	: 500 mm
Depth	: 350 mm
Height	: 265 mm
Grill power	: 2000 W
Oven power	: 1000 W
Max power	: 2000 W
Thermostat	: Electrical adjustable up to 300°C
Minute minder (available)	: Electrical adjustable to 100 minute
Against risk of fire class	: A



The datas and values about this product are obtained in laboratory test conditions therefore these values can be changed according to the usage and working conditions.

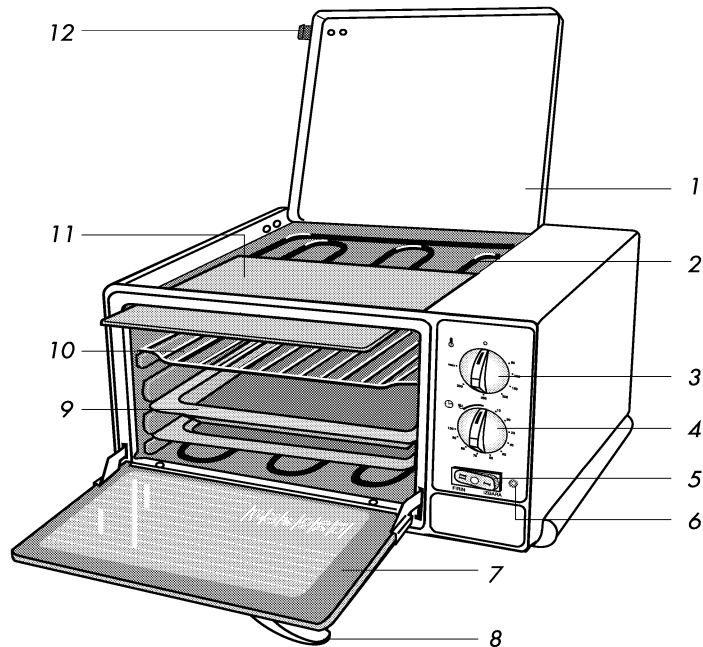

- | | |
|--------------------------|----------------------|
| 1. Top lid | 8. Front door handle |
| 2. Grill heating element | 9. Tray |
| 3. Thermostat knob | 10. Grill shelf |
| 4. Minute minder knob | 11. Reflector |
| 5. Switch | 12. Handle |
| 6. Thermostat lamp | |
| 7. Front door | |

2 Safety precaution and important items

! This product has been designed for only homes.

- * The current value of the fuse in your home shall be suitable to the current drawn by your cooker.
 - * Before your appliance is connected to the mains electricity supply, check to ensure that the voltage and the frequency shown in the data plate corresponds with your power supply.
 - * Our company shall not held responsible for any damage caused by the utilisation of the cooker without ground cabling.
- This appliance must be earthed.**
- * The mains lead must not come in contact with any part of the appliance which is hot during operation.
 - * During operation of this appliance the door and outer surfaces will get hot. Take care not to touch hot surfaces during use.
 - * The appliance must not be put on heat-sensitive surfaces (i.e. refrigerator, dishwasher or other pastic surfaces) because, during operation of appliance it can damage such surfaces.
 - * Thermostat signal lamp can light be on slightly when the appliance is connected to the mains electricity, and while it doesn't run. If you change the plug position (i.e. make it upside-down), this light be off. This has no effect on product safety.
 - * Before cleaning your cooker, plug off power cable from mains electricity supply.
 - * Location of cooker can be changed when cooker is cold.
 - * Pull stainless steel reflector tray in with two sides upside down when you close upper door of cooker.
 - * When your cooker is hot, don't drop any water droplet onto door glass. If so glass can crack.



* Keep your children away from the parts are heated while grilling or when the oven is on. Before using your product take the packaging materials out.

The packaging materials can cause danger for the children.

*** A perceptible odor is going to emit from the insulation materials and heating elements.**

In order to burn off the protective coating remove shelf and baking tray and turn the oven control knob to 200°C and run the oven for approximately 30 minutes again fumes will be emitted as the protective coating is burnt off but this is quite normal.

*** Never touch the appliance with wet hands. If there is a water spillage, water droplets or condensation on the appliance, switch the appliance off and wipe it dry thoroughly.**

*** Always use oven gloves when removing the grill rack and dishes from inside the oven when in use.**

*** Always switch off the appliance from the mains when the appliance is not in use, before cleaning or in the unlikely event of a product failure becoming apparent.**

3 Using of the oven

Introduction of control panel and using of the oven

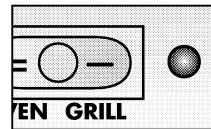
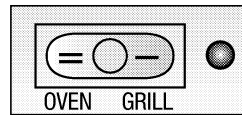
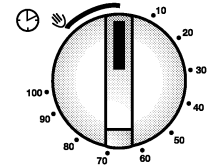
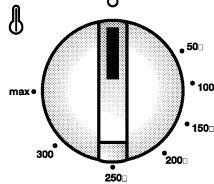
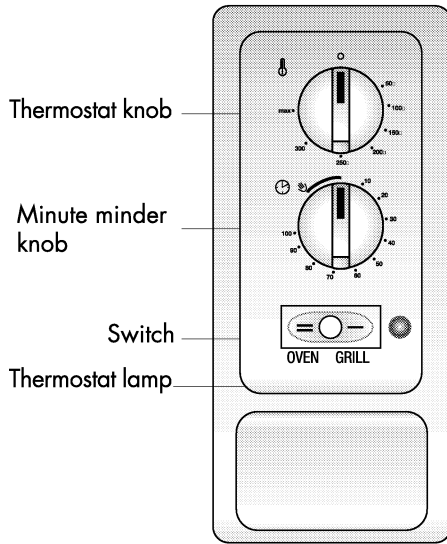

Thermostat knob

Adjustment by temperature in the oven by using this knob.

Minute minder

It is a mechanical timer that adjust the cooking time up to 100 minutes.

The knob is brought to the desired position by turning to the right. When the adjusted time terminates a signal sound **“CHINN”** is heard and the electrical current is cut automatically.

Bring the knob to the manual “” position. If you have to operate your oven more than 100 minutes or if you wanted to adjusted time by yourself.

Switch

It has 3 positions and controls the heating elements

0 : Off positions

I : Grill heating element is on

II : The upper and lower heating elements are on

Thermostat lamp

When the temperature inside the oven is reached to the pre-set value, the thermostat will make the system and the light be off.

When the temperature drops below the pre-set value, the thermostat makes the system and the light be on again.

The heating elements do not operate unless both the minute minder, heating control knob and the switch are on.

Operating the oven and grill

Adjust the minute minder and select Grill or oven position.

Then bring the thermostat knob to the proper position.

The heating elements will not be ON unless minute-minder and thermostat knob together selector switch are adjusted.

The reflector tray must be in the right position while cooking.

To cook on oven position

- ☛ Plug the cord to earthed socket.
- ☛ Adjust the minute-minder.
- ☛ Select the **“oven“** position by the selector switch.
- ☛ Bring the thermostat knob to the position as recommended in the cooking table.
- ☛ Pre-heat for 10 minutes.
- ☛ After pre-heating, put your cook on the shelf position as recommended.
- ☛ When the timer reached its adjusted time the time will ring and the current will be off automatically.
- ☛ Control your cook and then bring the selector switch to **“0“** position.

Do not use two tray at the same time while cooking.

cooking table

Food	Cooking temperature (degrees°C)	Cooking time (min)	Shelf position From bottom
Beef	250	40-50	2-3
Bread	200-220	20-30	2-3
Casseroles	150-170	20-30	2-3
Chicken	230	25-35	2-3
Fish	230	25-35	2-3
Lamb	230	25-30 (1)	2-3
Meringues	100-120	25-30	2-3
Milk pudding	140-160	20-25	2-3
Pastry	160-170	20-30	2-3
Pork	190-210	40-50	2
Quiches/Flans	160-180	35-45	2
Rich fruit cake	160-180	20-30	2-3
Scones	190-220	25-35	2-3
Sponge cake	160-180	30-40	1-2
Yorkshire pudding	200-220	20-30	2-3

(1) Suitable for 500 gr

Note: The values on the cooking table are the results we got in our laboratory.

The cooking table may be changed according to the quantity of products. You can find different tastes suitable for your harmony according to your cooking and using habits.

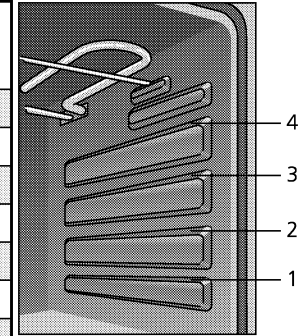

Shelf positions

Ensure you stand back from the appliance when opening the oven door to allow any build up of steam heat to escape.

Oven temperature chart (for guidance only) we recommend you follow manufactures recommendations whenever available

Important tips for making barbecue facility or grilling

1. You can make shish kebap or grilling above part of your oven. Moreover, you can make grilling into ovens in this case you must leave the oven's front door open.

2. The heating elements will not be ON unless minute-minder and thermostat knob together selector switch adjusted.

3. Locate a tray to the 3rd or 4th shelf in order to collect oils and for easy cleaning put some water in it.

While you are grilling oil drops can cause fire. Put away your oven from any flammable objects like curtains and covers. Never pour water on oil in flame.

Making barbecue (If available)

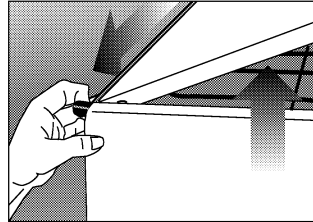
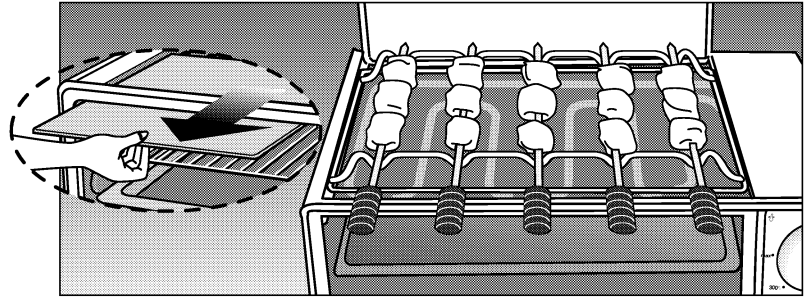

* Take out the reflector tray by putting your hand into oven than pull the tray out when your oven is cool.

* Place the spit house as you see on the figure.

* Locate a tray to the 3rd or 4th shelf in order to collect oils and for easy cleaning

put some water in it.

* Adjust the minder to the manual "👉" position.

* Select the grill position by the selector switch.

* Turn the thermostate knob to the "max" position.

* 2-3 minutes later insert your cooking to the spits.

* When you finish the cooking turn the selector switch "0" position.

* After you cleaned your oven while you are placing upper reflector, make sure that the holes, which are on the tray, are located on the backside or front site of the oven wall.

Grilling in the oven

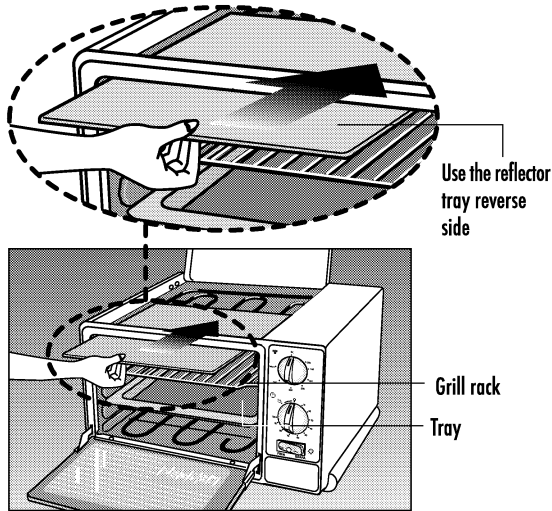

- * Plug the power cable.
- * Make sure that the reflector is on the right place.
- * Adjust the minder to the manual “” position.
- * Select the “**grill**” position by the selector switch.
- * Turn the thermostate knob to the “**max**” position.
- * Locate the grill shelf on the tray as you see on the figure and put your cook on the self.
- * Chose the correct self for the grill (3rd or 4th shelf is recommended) Leave the 3 cm to grill heating element.
- * When you finish the cooking turn the selector switch to “**0**” position.

Grilling on the oven (available)

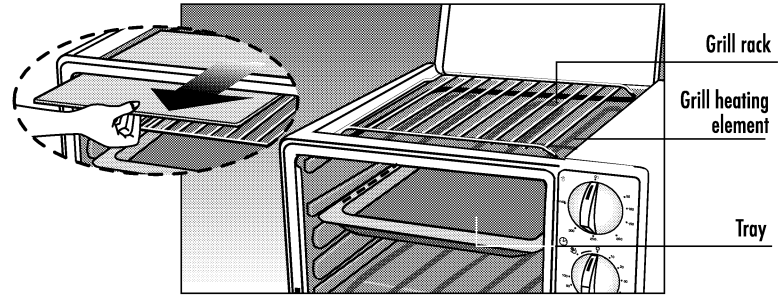



- * Take out reflector by putting your hand into oven than pull the tray out when your oven is cool.
- * Place the grill rack as you see on the figure.
- * Locate a tray to the 3rd or 4th shelf in order to collect oils and for easy cleaning put some water in it.
- * Adjust the minder to the manual “” position.
- * Select the grill position by the selector switch.
- * Turn the thermostate knob to the “**max**” position.
- * 2-3 minutes later put your cooking on the grill shelf.
- * When you finish the cooking turn the selector switch to “**0**” position.
- * After you cleaned your oven while you are placing upper reflector, make sure that the holes, which are on the tray, are located on the backside or front site of the wall.

Table 2

Foods	Grilling period	Grill and rack position
Beefsteak	5-7 min/one side	3-4
Beef	4-6 min/one side	3-4
Cutlet (lamb)	4-6 min/one side	4
Cutlet (calf)	5-7 min/one side	4
Meatballs	4-6 min/one side	4
Chicken (choped)	13-15 min/one side	3-4
Fish fillet	10-12 min/one side	4
Grilled fish	8-10 min/one side	3-4
Grilled sardine	10-13 min/one side	4

Adjust the minute minder to the “” position selector switch to the “**Grill**” and the thermostat knob to the “**max**” position.

Future transportation

When transportation is required;

- 1.** Transport in its original box if possible, follow the instructions stated on the box.
- 2.** If the original box is not available, fix the grill and baking tray with tapes or fill the interior with paper, in order to avoid undesired back and forth movement. Also tape the front door.
- 3.** Take necessary precautions against damages to front door window and other surfaces. Do not place loads, heavier than its own weight, on it.
- 4.** Keep the product at its normal position during transportation.

4 Cleaning and care

Before cleaning always switch your cooker off at the socket outlet and pull out the plug.

Warning !

- * Make sure that the oven, grill and steam vent are cool before you start cleaning.
- * Do not immerse your cooker in water.

Use a damp cloth to clean the interior and exterior. Never use any sharp instruments, abrasive household cleaner, or detergents for cleaning. For hard stains use suitable washing liquid.

We recommend that grill elements be wiped with a damp cloth to remove any fat splashes. This will prevent fumes for any fat being burnt off when the cooker is next used. Again before cleaning ensure the grill elements are cool.

It is recommended that the acidic matters such as oil, lemon etc. should be cleaned immediately.

Note: Even though grease and other foodstuff may leave marks on hobs when

baked on, they will not affect the performance of the appliance under normal conditions.

Cleaning Interior of your oven

Before switching on again ensure that all controls are in the OFF position. Take out all trays and the grill out of the oven. Clean out the interior with a piece of moist, soapy cloth. Then, clean it once more with a wet piece of cloth and let it to dry.

Do not use dry powder agents for cleaning. Special cleaners that are commercially available may be used after carefully reading the warning that are written on the labels.

Never clean the inside of the oven and trays by using materials such as hard brushes, steel pads or knives.

Do not use cleaning agents containing acid or chlorine on stainless steel surfaces and the handle. Cleaning can be accomplished using a soft piece of cloth wetted with soapy water or with commercially available special surface cleaners and a soft piece of cloth.