



*MF 6 midi oven*

*Instruction  
manual*



**This product ,  
is produced in modern facilities which  
are respectful to environment,without  
giving harm to the nature**

---

Dear Customer,

It is our ultimate desire that you achieve the best performance from our product, which has been passed through meticulous quality control checks and is manufactured in modern facilities.

**To this effect, we recommend that you read the entire guide carefully before operating the product and keep it as a reference.**



This product has 10 years life span.

It means that said period is time interval to stock its spare parts to keep this product functional.



# Contents

---

<b>1</b>	<b>Technical specifications</b>	<b>Page 2</b>
----------	---------------------------------	---------------

<b>2</b>	<b>Safety precaution and important items</b>	<b>Page 3</b>
----------	--	---------------

<b>3</b>	<b>Using of the cooker</b>	<b>Page 5</b>
----------	----------------------------	---------------

Introducing the control panel.....	5
Using of the cooker .....	6-7
Transport .....	8

<b>4</b>	<b>Maintenance and cleaning</b>	<b>Page 9</b>
----------	---------------------------------	---------------

# 1 Technical specifications

Width	: 595 mm
Depth	: 415 mm
Height	: 370 mm
Supply voltage	: 220 V~ 50 Hz
Lamp (available)	: 25 W
Oven wattage	: 1200 W
Grill wattage	: 2400 W
Total power	: 2425 W (Maximum)
Thermostat	: Adjustable to 250°C
Minute minder	: Electrical, adjust the cooking period to 100 min
Against risk of fire class	: A

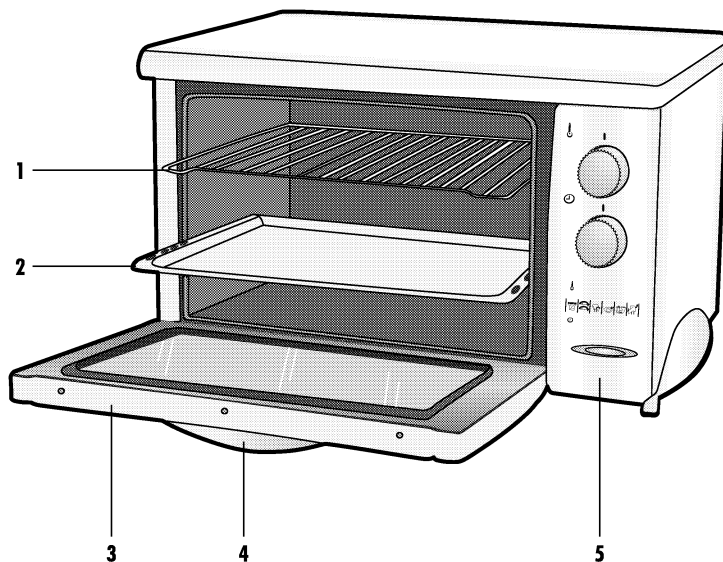

The data and values about this product are obtained in laboratory test conditions therefore these values can be changed according to the usage and working conditions.

- 1. Grill helf
- 2. Tray
- 3. Front door
- 4. Handle
- 5. Control panel

## 2 Safety precaution and important items

### ! This product has been designed for only homes.

- \* The current value of the fuse in your home shall be suitable to the current drawn by your cooker.
- \* Before your appliance is connected to the mains electricity supply, check to ensure that the voltage and the frequency shown in the data plate corresponds with your power supply.
- \* Our company shall not held responsible for any damage caused by the utilisation of the cooker without ground cabling.
- \* Before your appliance is connected to the mains electricity supply, check to ensure that the voltage and the frequency corresponds with your power supply.  
This appliance must be earthed.
- \* The mains lead must not come in contact with any part of the appliance which is hot during operation.
- \* During operation of this appliance the door and outer surfaces will get hot. Take care not to touch hot surfaces during use.



- \* Keep your children away from the parts are heated while grilling or when the oven is on.  
Before using your product take the packaging materials out.

The packaging materials can cause danger for the children.

### \* A perceptible odor is going to emit from the insulation materials and heating elements.

**In order to burn off the protective coating remove shelf and baking tray and turn the oven control knob to 200°C and run the oven for approximately 15 minutes again fumes will be emitted as the protective coating is burnt off but this is quite normal.**

**\* Never touch the appliance with wet hands. If there is a water spillage, water droplets or condensation on the appliance, switch the appliance off and wipe it dry thoroughly.**

**\* Always use oven gloves when removing the grill rack and dishes from inside the oven when in use.**

**\* Always switch off the appliance from the mains when the appliance is not in use, before cleaning or in the unlikely event of a product failure becoming apparent.**

### 3 Using of the oven

#### Introduction of control panel and using of the oven

**Warning! The heating elements do not operate unless both the minute minder and heating control knob are on.**  
**The thermostat lamp is illuminate when the oven or grill function are run.**

#### 1. Oven operation

The oven is thermostatically controlled.

Temperature adjustment of the oven is operated by turning the oven/grill knob in a clockwise direction.

Temperature settings may be made from 100°C to 250°C.

When the control knob is “☐” position, grill heater is on.

#### 2. Minute minder

It is a mechanical timer that adjust the cooking time up to 100 minutes.

The knob is brought to the desired position by turning to the right. When the adjusted time terminates a signal sound “CHINN” is heard and the electrical current is cut automatically.

Bring the knob to the manual “🌀” position. If you have to operate your oven more than 100 minutes or if you wanted to adjusted time by yourself.

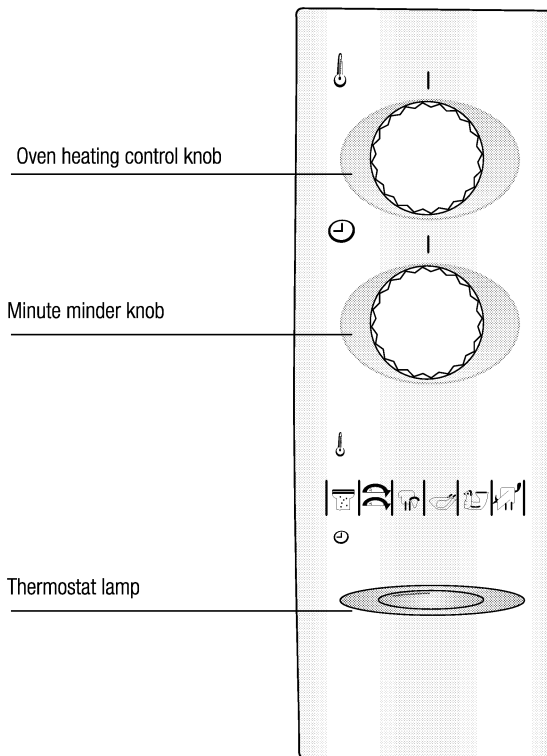

## To cook on oven position

- ☛ Plug the cord to earthed socket.
  - ☛ Adjust the minute-minder.
  - ☛ Bring the thermostat knob to the position as recommended in the cooking table. The light will continue to illuminate until the preset temperature set using the temperature control knob is reached. Once the temperature has been reached the amber light will go off and then cycle on and off during use to maintain the pre-set temperature.
- We recommend you to reduce cooking times compared to full size cookers by about 1/5 and then ensure the food is cooked properly (eg: piping hot)
- ☛ Pre-heat for 10 minutes.
  - ☛ After pre-heating, put your cook on the shelf position as recommended.
  - ☛ When the timer reached its adjusted time the time will ring and the current will be off automatically.

### cooking table

Food	Cooking temperature (degrees°C)	Cooking time (min)	Shelf position From bottom
Beef	250	40-50	2-3
Bread	200-220	20-30	2-3
Casseroles	150-170	20-30	2-3
Chicken	230	25-35	2-3
Fish	230	25-35	2-3
Lamb	230	25-30 (1)	2-3
Meringues	100-120	25-30	2-3
Milk pudding	140-160	20-25	2-3
Pastry	160-170	20-30	2-3
Pork	190-210	40-50	2
Quiches/Flans	160-180	35-45	2
Rich fruit cake	160-180	20-30	2-3
Scones	190-220	25-35	2-3
Sponge cake	160-180	30-40	1-2
Yorkshire pudding	200-220	20-30	2-3

#### (1) Suitable for 500 gr

Oven temperature chart (for guidance only) we recommend you follow manufactures recommendations whenever available

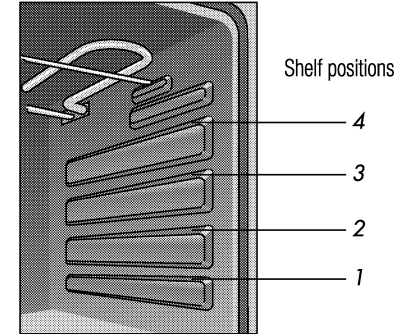

Ensure you stand back from the appliance when opening the oven door to allow any build up of steam heat to escape.

Note: The values on the cooking table are the results we got in our laboratory. The cooking table may be changed according to the quantity of products. You can find different tastes suitable for your harmony according to your cooking and using habits.

## Grill operation



### Important!

When using the grill, the oven door must always be left open. Otherwise grill will not operate.



### Caution:

Accessible parts may become hot when the grill is in use. Children should be kept away.

- ☛ To operate the grill, turn the oven/grill knob in a clockwise direction until the grill symbol “” which is located to the top left handside of the knob.
- ☛ Adjust the minder to the manual “” position.
- ☛ **Preheat the grill for 5 minutes then;**
- ☛ Apply oil on the grill shelf to prevent meat from sticking on the bars.
- ☛ Locate a tray to the 2<sup>nd</sup> or 3<sup>rd</sup> in order to collect oils and for easy cleaning put some water in it.

## Grilling table

Foods	Grilling period	Grill and rack position
Beefsteak	5-7 min/one side	3-4
Beef	4-6 min/one side	3-4
Cutlet (lamb)	4-6 min/one side	4
Cutlet (calf)	5-7 min/one side	4
Meatballs	4-6 min/one side	4
Chicken (choped)	13-15 min/one side	3-4
Fish fillet	10-12 min/one side	4
Grilled fish	8-10 min/one side	3-4
Grilled sardine	10-13 min/one side	4

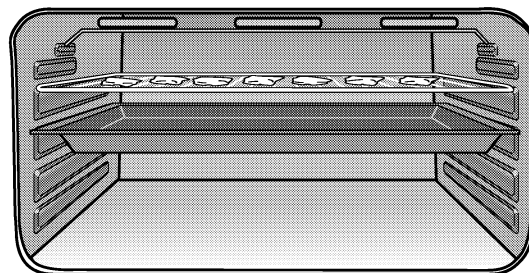

## **Futura transportation**

### **When transportation is required;**

1. Transport in its original box if possible, follow the instructions stated on the box.
2. If the original box is not available, fix the grill and baking tray with tapes or fill the interior with paper, in order to avoid undesired back and forth movement. Also tape the front door.
3. Take necessary precautions against damages to front door window and other surfaces. Do not place loads, heavier than its own weight, on it.
4. Keep the product at its normal position during transportation.

## 4 Cleaning and care

Before cleaning always switch your cooker off at the socket outlet and pull out the plug.

### Warning !

- \* Make sure that the oven, grill and steam vent are cool before you start cleaning.
- \* Do not immerse your cooker in water.

Use a damp cloth to clean the interior and exterior. Never use any sharp instruments, abrasive household cleaner, or detergents for cleaning. For hard stains use suitable washing liquid.

We recommend that grill elements be wiped with a damp cloth to remove any fat splashes. This will prevent fumes for any fat being burnt off when the cooker is next

used. Again before cleaning ensure the grill elements are cool.

It is recommended that the acidic matters such as oil, lemon etc. should be cleaned immediately.

Note: Even though grease and other foodstuff

may leave marks on hobs when baked on, they will not affect the performance of the appliance under normal conditions.

### Cleaning Interior of your oven

Before switching on again ensure that all controls are in the OFF position. Take out all trays and the grill out of the oven. Clean out the interior with a piece of moist, soapy cloth. Then, clean it once more with a wet piece of cloth and let it dry.

Do not use dry powder agents for cleaning. Special cleaners that are commercially available may be used after carefully reading the warning that are written on the labels.

Never clean the inside of the oven and trays by using materials such as hard brushes, steel pads or knives.

Do not use cleaning agents containing acid or chlorine on stainless steel surfaces and the handle. Cleaning can be accomplished using a soft piece of cloth wetted with soapy water or with commercially available special surface cleaners and a soft piece of cloth.

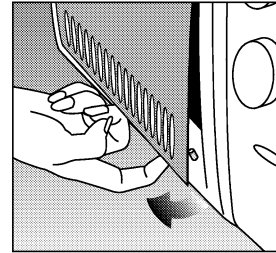

### If you want to remove and clean “the plastic cover”

Release the plastic protection cover by fitting it between the front door and protection, near to the notches, with your hand or something like a straight instrument (e.g. head of a spoon). Later on, release it, and also remove from the top notches, and take it out. Clean the plastic protection cover only with liquid type cleaners. Never use hard materials while locating the protection to its place, first locate it to the upper notches, then fit it to the bottom notches. Control whether it is fit to the notches by opening the door and looking from the glass.

### Replacing the oven lamp: (In models with lamp)

1. Unplug the power cable.
2. Then, remove the protective glass cover of the lamp inside your oven by turning it counterclockwise.
3. Then, remove the bulb by turning it counterclockwise.
4. After installing the correct bulb obtained from an Authorized Service, reinstall the protective glass of the lamp.