



Built-In Oven
9681 STI

Please read this user manual first!

Dear Customer,

Thank you for purchasing this Arçelik product. We hope that you get the best results from your product which has been manufactured with high quality and state-of-the-art technology. Therefore, please read this entire user manual and all other accompanying documents carefully before using the product and keep it as a reference for future use. If you handover the product to someone else, give the user manual as well. Follow all warnings and information in the user manual.

Remember that this user manual is also applicable for several other models. Differences between models will be identified in the manual.

Explanation of symbols

Throughout this user manual the following symbols are used:



Important information or useful hints about usage.



Warning of hazardous situations with regard to life and property.



Warning of electric shock.



Warning of risk of fire.



Warning of hot surfaces.

TABLE OF CONTENTS

1 Important instructions and warnings for safety and environment 4

General safety.....	4
Electrical safety.....	4
Product safety.....	5
Intended use.....	6
Safety for children.....	6
Compliance with AEEE regulation and disposal of waste products.....	7
Package information.....	7

2 General information 8

Overview.....	8
Package contents.....	9
Technical specifications.....	10

3 Installation 11

Before installation.....	11
Installation and connection.....	13
Future Transportation.....	14

4 Preparation 16

Tips for saving energy.....	16
Initial use.....	16
Day time.....	16
First cleaning of the appliance.....	17

Initial heating.....	17
----------------------	----

5 How to operate the oven 18

General information on baking, roasting and grilling.....	18
How to operate the electric oven.....	18
Operating modes.....	21
How to operate the oven control unit.....	23
Using the keylock.....	25
Using the clock as an alarm.....	26
Cooking times table.....	26
Ready meals functions.....	28
Settings menu.....	31
How to operate the grill.....	32
Cooking times table for grilling.....	33

6 Maintenance and care 34

General information.....	34
Cleaning the control panel.....	34
Cleaning the oven.....	34
Removing the oven door.....	36
Removing the door inner glass.....	36
Replacing the oven lamp.....	37

7 Troubleshooting 38

1 Important instructions and warnings for safety and environment

This section contains safety instructions that will help protect from risk of personal injury or property damage. Failure to follow these instructions shall void any warranty.

General safety

- This appliance can be used by children aged from 8 years and above and persons with reduced physical, sensory or mental capabilities or lack of experience and knowledge if they have been given supervision or instruction concerning use of the appliance in a safe way and understand the hazards involved.

Children shall not play with the appliance. Cleaning and user maintenance shall not be made by children without supervision.

- Installation and repair procedures must always be performed by Authorized Service Agents. The manufacturer shall not be held responsible for damages arising from procedures carried out by unauthorized persons which may also void the warranty. Before installation, read the instructions carefully.
- Do not operate the product if it is defective or has any visible damage.

- Control that the product function knobs are switched off after every use.

Electrical safety

- If the product has a failure, it should not be operated unless it is repaired by the Authorized Service Agent. There is the risk of electric shock!
- Only connect the product to a grounded outlet/line with the voltage and protection as specified in the “Technical specifications”. Have the grounding installation made by a qualified electrician while using the product with or without a transformer. Our company shall not be liable for any problems arising due to the product not being earthed in accordance with the local regulations.
- Never wash the product by spreading or pouring water onto it! There is the risk of electric shock!
- never touch the plug with wet hands! Never unplug by pulling on the cable, always pull out by grabbing the plug.
- The product must be unplugged during installation, maintenance, cleaning and repairing procedures.

- If the power connection cable for the product is damaged, it must be replaced by the manufacturer, its service agent or simillary qualified persons in order to avoid a hazard.
- The appliance must be installed so that it can be completely disconnected from the network. The separation must be provided either by a mains plug, or a switch built into the fixed electrical installation, according to construction regulations.
- Rear surface of the oven gets hot when it is in use. Make sure that the electrical connection does not contact the rear surface; otherwise, connections can get damaged.
- Do not trap the mains cable between the oven door and frame and do not route it over hot surfaces. Otherwise, cable insulation may melt and cause fire as a result of short circuit.
- Any work on electrical equipment and systems should only be carried out by authorized and qualified persons.
- In case of any damage, switch off the product and disconnect it from the mains. To do this, turn off the fuse at home.
- Make sure that fuse rating is compatible with the product.

Product safety

- The appliance and its accessible parts become hot during use. Care should be taken to avoid touching heating elements. Children less than 8 years of age shall be kept away unless continuously supervised.
- Never use the product when your judgment or coordination is impaired by the use of alcohol and/or drugs.
- Be careful when using alcoholic drinks in your dishes. Alcohol evaporates at high temperatures and may cause fire since it can ignite when it comes into contact with hot surfaces.
- Do not place any flammable materials close to the product as the sides may become hot during use.
- During use the appliance becomes hot. Care should be taken to avoid touching heating elements inside the oven.
- Keep all ventilation slots clear of obstructions.
- Do not heat closed tins and glass jars in the oven. The pressure that would build-up in the tin/jar may cause it to burst.
- Do not place baking trays, dishes or aluminium foil directly onto the bottom of the oven. The heat

accumulation might damage the bottom of the oven.

- Do not use harsh abrasive cleaners or sharp metal scrapers to clean the oven door glass since they can scratch the surface, which may result in shattering of the glass.
- Do not use steam cleaners to clean the appliance as this may cause an electric shock.
- Use the shelves as described in "How to operate the electric oven".
- Do not use the product if the front door glass removed or cracked.
- Oven handle is not towel dryer. Do not hang up towel, gloves, or similar textile products when the grill function is at open door.
- Always use heat resistant oven gloves when putting in or removing dishes into/from the hot oven.
- Ensure that the appliance is switched off before replacing the lamp to avoid the possibility of electric shock.

For the reliability of the fire of the product;

- Make sure the plug is fitting to socket as well for not cause to spark.
- Do not use damaged or cutted or extension cable except the original cable.

- Make sure that not whether liquid or moisture on the socket is plugged to product .

Intended use

- This product is designed for domestic use. Commercial use will void the guarantee.
- This appliance is for cooking purposes only. It must not be used for other purposes, for example room heating.
- This product should not be used for warming the plates under the grill, drying towels, dish cloths etc. by hanging them on the oven door handles. This product should also not be used for room heating purposes.
- The manufacturer shall not be liable for any damage caused by improper use or handling errors.
- The oven can be used for defrosting, baking, roasting and grilling food.
- Service life of your product is 10 years. Manufacturer shall provide the required spare parts for the product to perform as defined during this period.

Safety for children

- Accessible parts may become hot during use. Young children should be kept away.
- The packaging materials will be dangerous for children. Keep the packaging materials away from

children. Please dispose of all parts of the packaging according to environmental standards.

- Electrical products are dangerous to children. Keep children away from the product when it is operating and do not allow them to play with the product.
- Do not place any items above the appliance that children may reach for.
- When the door is open, do **not** load any heavy object on it and do **not** allow children to sit on it. It may overturn or door hinges may get damaged.

Compliance with AEEE regulation and disposal of waste products

- This product does not contain harmful and forbidden materials described in the "Directive on the Restriction of the Use of Certain Hazardous Substances in Waste Electrical and Electronic Equipment" (AEEE) issued by the T.R. Ministry of Environment and Urbanization.

Complies with the AEEE Directive.



- This product has been manufactured with high quality

parts and materials which can be reused and are suitable for recycling. Therefore, do not dispose the product with normal domestic waste at the end of its service life. Take it to a collection point for the recycling of electrical and electronic equipment. Please consult your local authorities to learn the nearest collection point. Help protect the environment and natural resources by recycling used products. Before disposing of the product, cut off the power cable plug and make the door lock (if any) unusable to avoid dangerous conditions to children.

Package information

- Packaging materials of the product are manufactured from recyclable materials in accordance with our National Environment Regulations. Do not dispose of the packaging materials together with the domestic or other wastes. Take them to the packaging material collection points designated by the local authorities.

2 General information

Overview

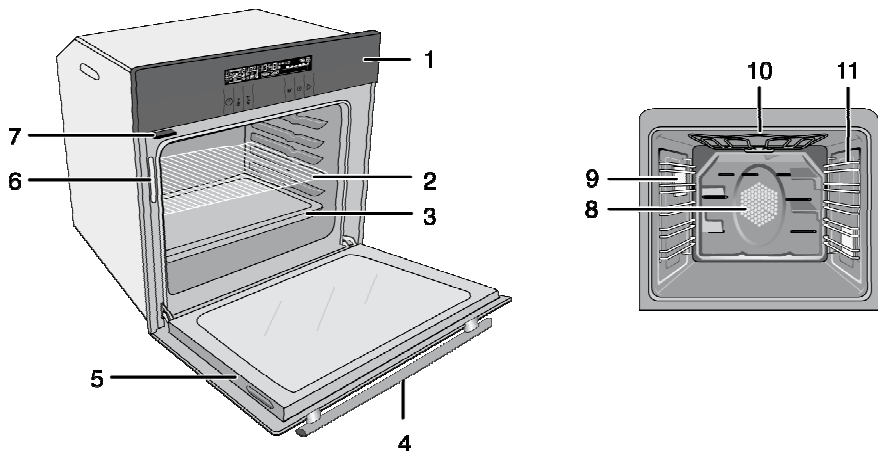

- | | | | |
|---|-----------------------|----|--------------------------------|
| 1 | Control panel | 7 | Pitcher |
| 2 | Wire shelf | 8 | Fan motor (behind steel plate) |
| 3 | Tray | 9 | Lamp |
| 4 | Handle | 10 | Top heating element |
| 5 | Front door | 11 | Shelf positions |
| 6 | Water level indicator | | |

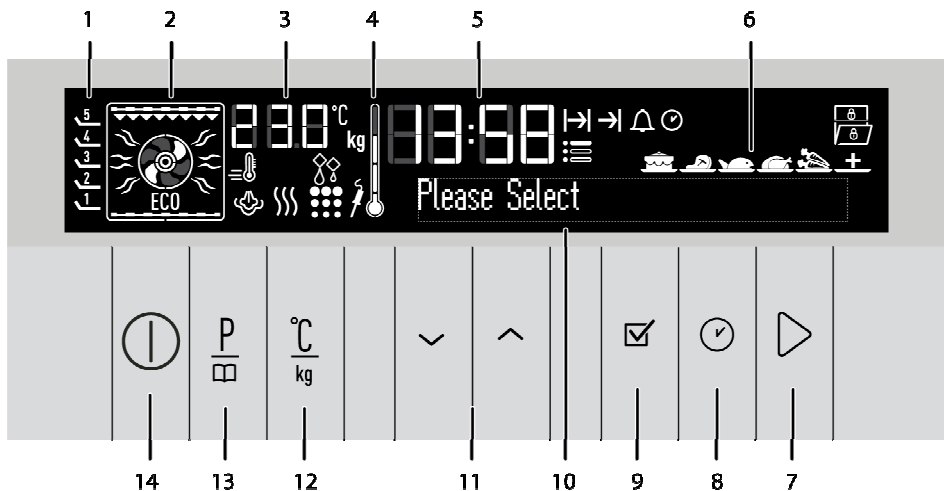

- | | | | |
|---|------------------------------------|----|--|
| 1 | Shelf positions | 8 | Time and settings key |
| 2 | Function display | 9 | OK key |
| 3 | Temperature/weight indicator field | 10 | Text display |
| 4 | Oven Inner Temperature symbol | 11 | Up/down keys (Menu step) |
| 5 | Current time indicator field | 12 | Temperature/weight/booster setting key |
| 6 | Convenience food selection display | 13 | Program selection key |
| 7 | Start/stop cooking key | 14 | ON/OFF key |

Package contents



Accessories supplied can vary depending on the product model. Not every accessory described in the user manual may exist on your product.

1. **User manual**

2. **Oven tray**

Used for pastries, frozen foods and big roasts.



3. **Deep tray**

Used for pastries, large roasts, juicy dishes, and for collecting the fat while grilling.



4. **Cake tray**

Used for pastries such as cookies and biscuits.



5. **Wire Shelf**

Used for roasting and for placing the food to be baked, roasted or cooked in casserole dishes to the desired rack.

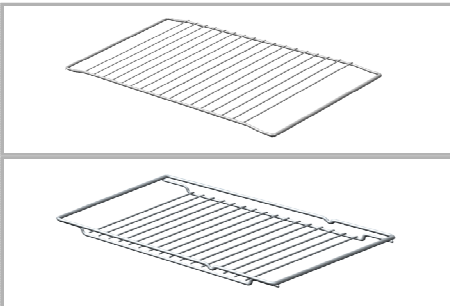

6. **Placing the wire shelf and tray onto the telescopic racks properly**

Telescopic racks allow you to install and remove the trays and wire shelf easily. When using the tray and wire shelf with telescopic racks, make sure that the pins at the rear section of the telescopic rack stands against the edges of the wire shelf and tray.

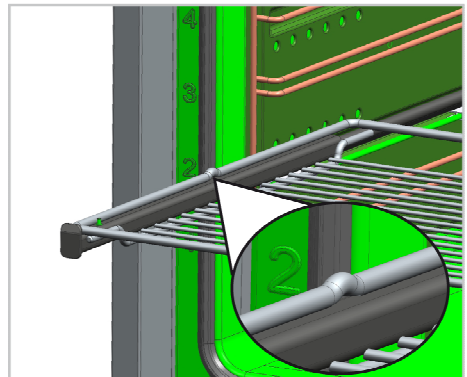
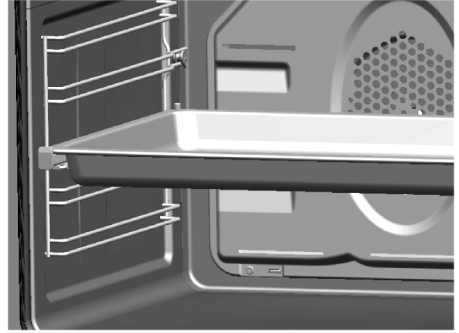

7. **Placing the wire shelf and tray onto the wire racks properly**

Products without telescopic pull-out: With product without a telescopic pull-out, the baking tray and grill are pushed in with their edges between the runners on the side mounts.

It is important to place the wire shelf and/or tray onto the rack properly. Slide the wire shelf or tray between 2 rails and make sure that it is balanced before placing food on it (Please see the following figure).

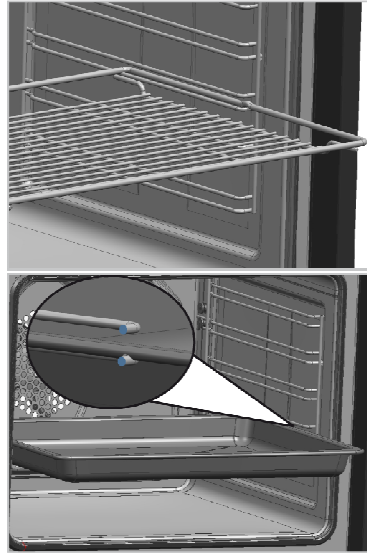

Technical specifications

Voltage / frequency	220-240 V ~ 50 Hz
Total power consumption	3,1kW
Fuse	min. 16 A
Cable type / section	H05VV-FG 3 x 1,5 mm ²
Cable length	max. 2 m
External dimensions (height / width / depth)	595 mm/594 mm/567 mm
Installation dimensions (height / width / depth)	**590 or 600 mm/560 mm/min. 550 mm
Main oven	Multifunction oven
Energy efficiency class [#]	A
Inner lamp	15/25 W
Grill power consumption	2,2 kW

[#] Basics: Information on the energy label of electrical ovens is given in accordance with the EN 50304 standard. Those values are determined under standard load with bottom-top heater or fan assisted heating (if any) functions.

Energy efficiency class is determined in accordance with the following prioritization depending on whether the relevant functions exist on the product or not. 1-Cooking with eco-fan, 2- Turbo slow cooking, 3- Turbo cooking, 4- Fan assisted bottom/top heating, 5-Top and bottom heating.

** See. *Installation*, page 11.

 Technical specifications may be changed without prior notice to improve the quality of the product.

 Figures in this manual are schematic and may not exactly match your product.

 Values stated on the product labels or in the documentation accompanying it are obtained in laboratory conditions in accordance with relevant standards. Depending on operational and environmental conditions of the product, these values may vary.

3 Installation

Refer to the nearest Authorised Service Agent for installation of the product. Make sure that the electric and gas installations are in place before calling the Authorised Service Agent to have the product ready for operation. If not, call a qualified electrician and fitter to have the required arrangements made. The manufacturer shall not be held responsible for damages arising from procedures carried out by unauthorized persons which may also void the warranty.



Preparation of location and electrical installation for the product is under customer's responsibility.



DANGER:

The product must be installed in accordance with all local electrical regulations.



DANGER:

Prior to installation, visually check if the product has any defects on it. If so, do not have it installed.

Damaged products cause risks for your safety.

Before installation

The appliance is intended for installation in commercially available kitchen cabinets. A safety distance must be left between the appliance and the kitchen walls and furniture. See figure (values in mm).

- Surfaces, synthetic laminates and adhesives used must be heat resistant (100 °C minimum).
- Kitchen cabinets must be set level and fixed.
- If there is a drawer beneath the oven, a shelf must be installed between oven and drawer.
- Carry the appliance with at least two persons.



Do not install the appliance next to refrigerators or freezers. The heat emitted by the appliance will lead to an increased energy consumption of cooling appliances.



The door and/or handle must not be used for lifting or moving the appliance.



If the appliance has wire handles, push the handles back into the side walls after moving the appliance.

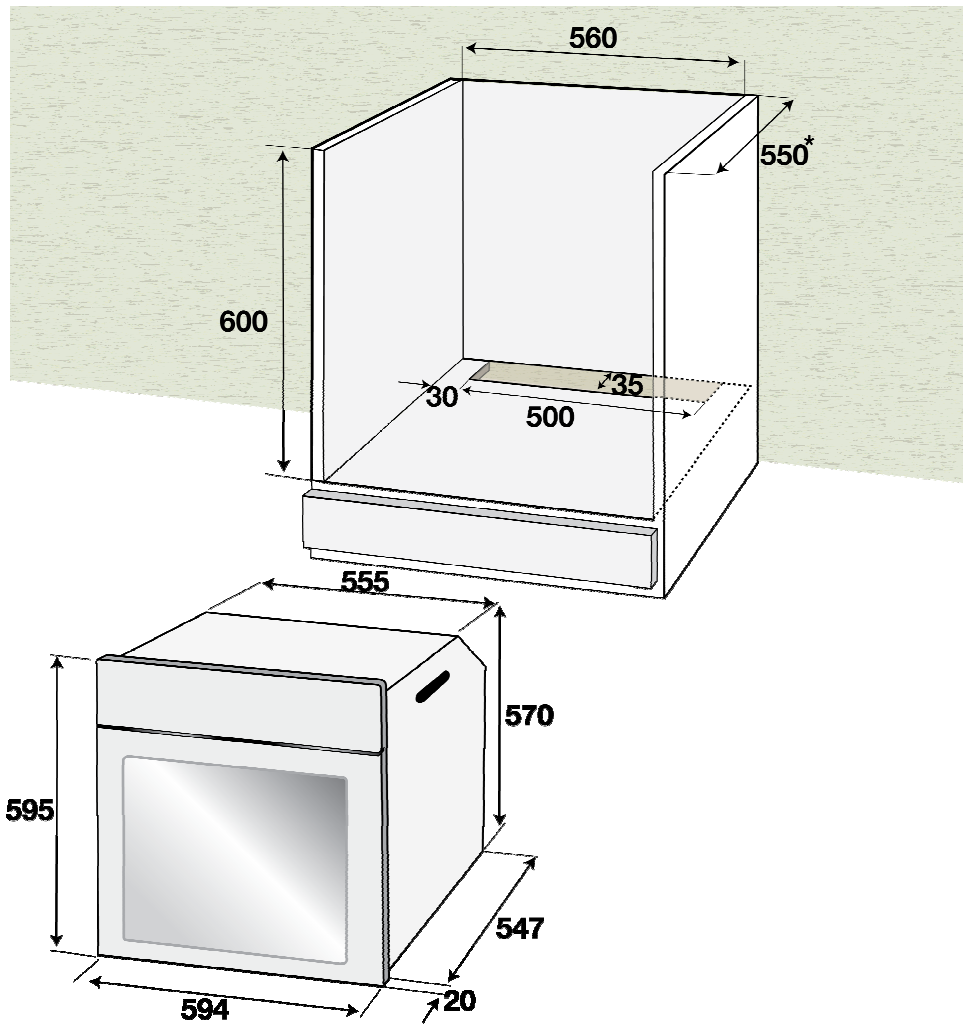

* min.

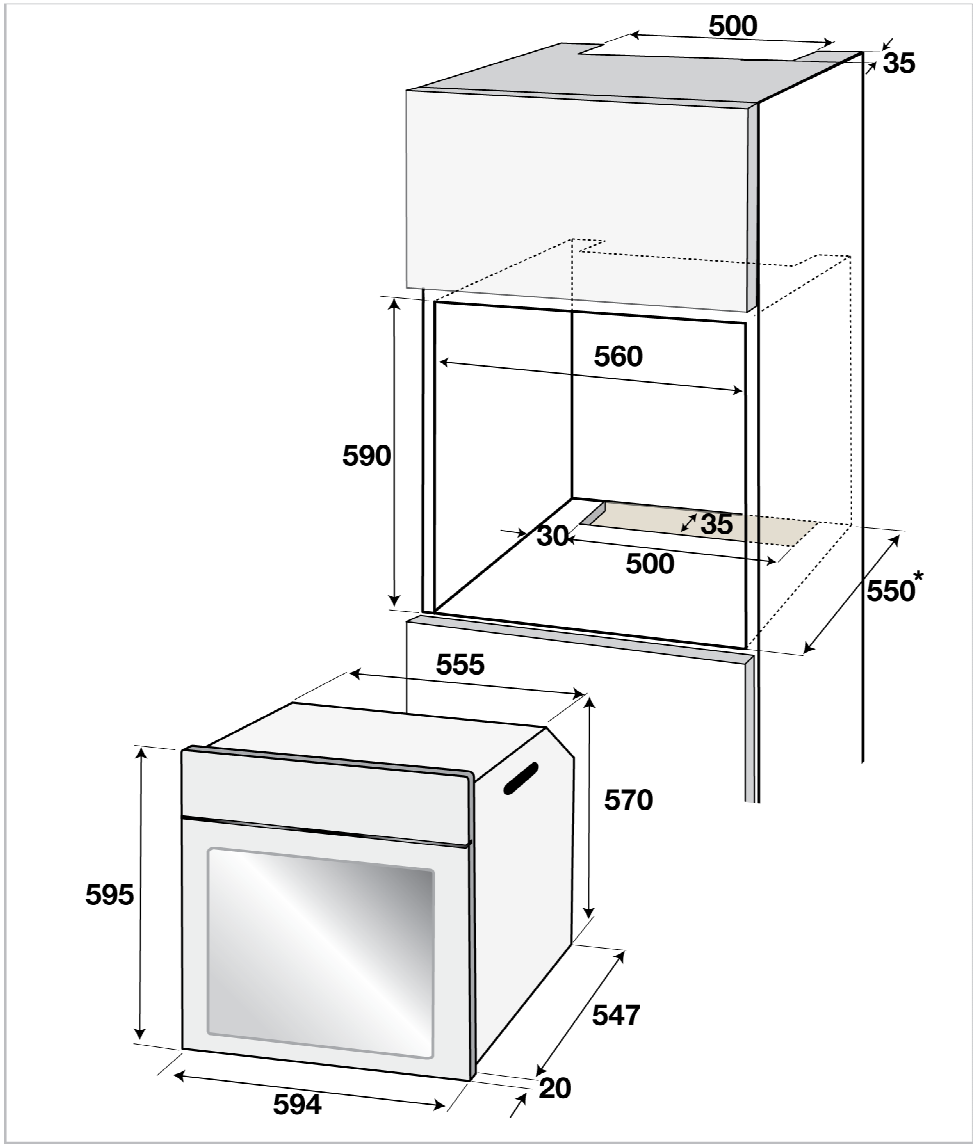

* min.

Installation and connection

- Product can only be installed and connected in accordance with the statutory installation rules.

Electrical connection

Connect the product to a grounded outlet/line protected by a fuse of suitable capacity as stated in the "Technical specifications" table. Have the

grounding installation made by a qualified electrician while using the product with or without a transformer. Our company shall not be liable for any damages that will arise due to using the product without a grounding installation in accordance with the local regulations.

**DANGER:**

The product must be connected to the mains supply only by an authorised and qualified person. The product's warranty period starts only after correct installation.

Manufacturer shall not be held responsible for damages arising from procedures carried out by unauthorised persons.

**DANGER:**

The power cable must not be clamped, bent or trapped or come into contact with hot parts of the product.

A damaged power cable must be replaced by an Authorised Service Agent. Otherwise, there is risk of electric shock, short circuit or fire!

- Connection must comply with national regulations.
- The mains supply data must correspond to the data specified on the type label of the product. Open the front door to see the type label.
- Power cable of your product must comply with the values in "Technical specifications" table.

**DANGER:**

Before starting any work on the electrical installation, disconnect the product from the mains supply. There is the risk of electric shock!



Power cable plug must be within easy reach after installation (do not route it above the hob).

Plug the power cable into the socket.

Installing the product

1. Slide the oven into the cabinet, align and secure it while making sure that the power cable is not broken and/or trapped.

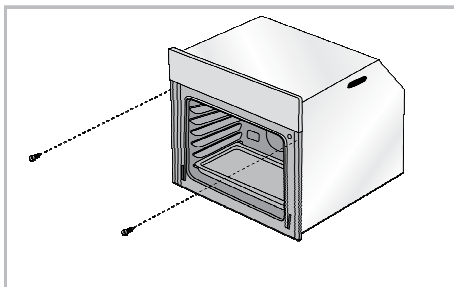

Secure the oven with 2 screws as illustrated.

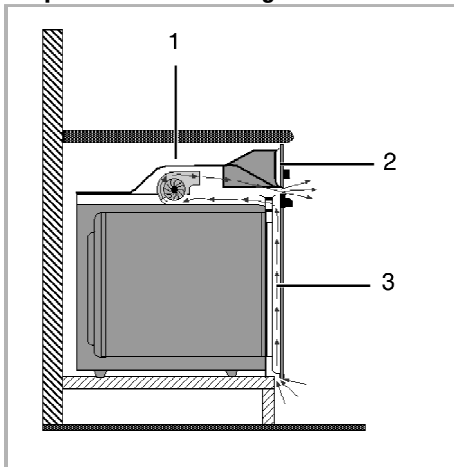
For products with cooling fan

- 1 Cooling fan
- 2 Control panel
- 3 Door

The built-in cooling fan cools both the built-in cabinet and the front of the product.



Cooling fan continues to operate for about 20-30 minutes after the oven is switched off.

Final check



1. Plug in the power cable and switch on the product's fuse.
2. Check the functions.

Future Transportation

- Keep the product's original carton and transport the product in it. Follow the instructions on the carton. If you do not have the original carton, pack the product in

- bubble wrap or thick cardboard and tape it securely.
- To prevent the wire grill and tray inside the oven from damaging the oven door, place a strip of cardboard onto the inside of the oven door that lines up with the position of the trays. Tape the oven door to the side walls.

- Do not use the door or handle to lift or move the product.

 Do not place any objects onto the product and move it in upright position.
 Check the general appearance of your product for any damages that might have occurred during transportation.

4 Preparation

Tips for saving energy

The following information will help you to use your appliance in an ecological way, and to save energy:

- Use dark coloured or enamel coated cookware in the oven since the heat transmission will be better.
- While cooking your dishes, perform a preheating operation if it is advised in the user manual or cooking instructions.
- Do not open the door of the oven frequently during cooking.
- Try to cook more than one dish in the oven at the same time whenever possible. You

can cook by placing two cooking vessels onto the wire shelf.

- Cook more than one dish one after another. The oven will already be hot.
- You can save energy by switching off your oven a few minutes before the end of the cooking time. Do not open the oven door.
- Defrost frozen dishes before cooking them.

Initial use

Day time



Before you can use the oven, the time must be set. If the time is not set, oven will not operate.

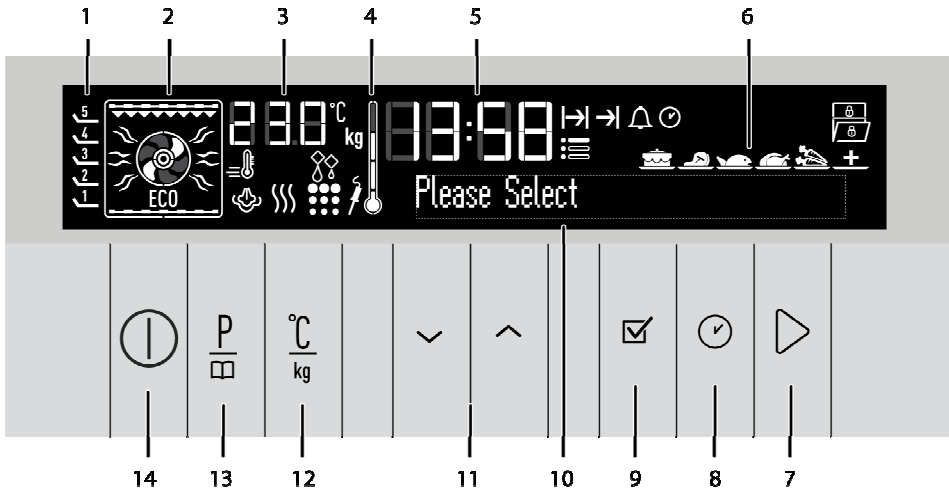

- 1 Shelf positions
- 2 Function display
- 3 Temperature/weight indicator field
- 4 Oven Inner Temperature symbol
- 5 Current time indicator field
- 6 Convenience food selection display
- 7 Start/stop cooking key
- 8 Time and settings key
- 9 OK key
- 10 Text display
- 11 Up/down keys (Menu step)
- 12 Temperature/weight/booster setting key
- 13 Program selection key

- 14 ON/OFF key







Language setting

Language can only be set when the oven is switched off.

1. Plug in the power cable and switch on the product's fuse.
2. When you switch on the oven for the first time, "Language: English" appears on the Text display
3. Touch keys to select the desired language.
4. Touch to confirm the setting.
» It returns to the stand-by display.

Set the time



1. After selecting the language, "Time setting" appears on the Text display and  symbol flash. Set the hour with  keys.
 2. Touch  to confirm the hour.
 3. Minute field and  symbol flash on the display. Touch  keys to set the minute. Touch  to confirm the minute.
- » It returns to the stand-by display. Only the current time appears on the display.

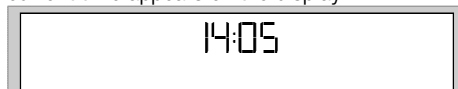

 In case of power outage or when the product is unplugged and plugged in again, time setting menu is displayed again. However, the set time is preserved in power outages shorter than 20 minutes. In such cases, you can continue by confirming the time value.

First cleaning of the appliance

 The surface might get damaged by some detergents or cleaning materials. Do not use aggressive detergents, cleaning powders/creams or any sharp objects during cleaning. Do not use harsh abrasive cleaners or sharp metal scrapers to clean the oven door glass since they can scratch the surface, which may result in shattering of the glass.

1. Remove all packaging materials.
2. Wipe the surfaces of the appliance with a damp cloth or sponge and dry with a cloth.

Initial heating

Heat up the product for about 30 minutes and then switch it off. Thus, any production residues or layers will be burnt off and removed.

 **WARNING**
Hot surfaces cause burns!
Product may be hot when it is in use. Never touch the hot burners, inner sections of the oven, heaters and etc. Keep children away. Always use heat resistant oven gloves when putting in or removing dishes into/from the hot oven.

Electric oven

1. Take all baking trays and the wire grill out of the oven.
2. Close the oven door.
3. Select Static position.
 1. Select the highest oven power; See *How to operate the electric oven, page 18*.
 2. Operate the oven for about 30 minutes.
 3. Turn off your oven; See *How to operate the electric oven, page 18*

Grill oven

1. Take all baking trays and the wire grill out of the oven.
2. Close the oven door.
3. Select the highest grill power; see *How to operate the grill, page 32*.
4. Operate the grill about 30 minutes.
5. Turn off your grill; see *How to operate the grill, page 32*

 Smoke and smell may emit for a couple of hours during the initial operation. This is quite normal. Ensure that the room is well ventilated to remove the smoke and smell. Avoid directly inhaling the smoke and the smell that emits.

5 How to operate the oven

General information on baking, roasting and grilling



WARNING

Hot surfaces cause burns!

Product may be hot when it is in use. Never touch the hot burners, inner sections of the oven, heaters and etc. Keep children away. Always use heat resistant oven gloves when putting in or removing dishes into/from the hot oven.



DANGER:

Be careful when opening the oven door as steam may escape. Exiting steam can scald your hands, face and/or eyes.

Tips for baking

- Use non-sticky coated appropriate metal plates or aluminum vessels or heat-resistant silicone moulds.
- Make best use of the space on the rack.
- Place the baking mould in the middle of the shelf.
- Select the correct rack position before turning the oven or grill on. Do not change the rack position when the oven is hot.
- Keep the oven door closed.

Tips for roasting

- Treating whole chicken, turkey and large piece of meat with dressings such as lemon juice and black pepper before cooking will increase the cooking performance.
- It takes about 15 to 30 minutes longer to roast meat with bones when compared to roasting the same size of meat without bones.

- Each centimeter of meat thickness requires approximately 4 to 5 minutes of cooking time.
- Let meat rest in the oven for about 10 minutes after the cooking time is over. The juice is better distributed all over the roast and does not run out when the meat is cut.
- Fish should be placed on the middle or lower rack in a heat-resistant plate.

Tips for grilling

When meat, fish and poultry are grilled, they quickly get brown, have a nice crust and do not get dry. Flat pieces, meat skewers and sausages are particularly suited for grilling as are vegetables with high water content such as tomatoes and onions.

- Distribute the pieces to be grilled on the wire shelf or in the baking tray with wire shelf in such a way that the space covered does not exceed the size of the heater.
- Slide the wire shelf or baking tray with grill into the desired level in the oven. If you are grilling on the wire shelf, slide the baking tray to the lower rack to collect fats. Add some water in the tray for easy cleaning.



Foods that are not suitable for grilling carry the risk of fire. Only grill food which is suitable for intensive grilling heat.

Do not place the food too far in the back of the grill. This is the hottest area and fatty food may catch fire.

How to operate the electric oven



Before you can use the oven, the time must be set. If the time is not set, oven will not operate.

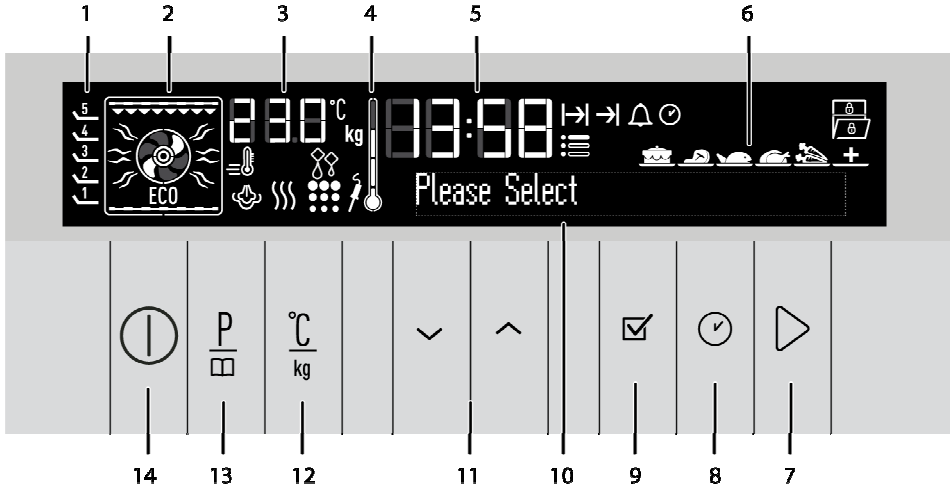

- 1 Shelf positions
- 2 Function display
- 3 Temperature/weight indicator field
- 4 Oven Inner Temperature symbol
- 5 Current time indicator field
- 6 Convenience food selection display
- 7 Start/stop cooking key
- 8 Time and settings key
- 9 OK key
- 10 Text display
- 11 Up/down keys (Menu step)
- 12 Temperature/weight/booster setting key
- 13 Program selection key
- 14 ON/OFF key

Display symbols:

- Rapid heating (Booster) symbol
- Cooking time symbol
- End of cooking time symbol
- Alarm symbol
- Current time symbol
- Settings symbol
- Defrost symbol
- Keylock symbol
- Door open symbol
- Meat probe symbol *
- Pyro symbol *
- Steam symbol *
- Varies depending on the product model.

Oven returns to stand-by display after it is switched on and the current time is set. Only the current time appears on the display. Only the and keys are functional when the display is in this status. You can perform all actions in the Settings menu. See *Settings menu*, page 31.

i If you touch key briefly in this screen, "Keep pressed for 1 second" warning appears in the text field. Touch the key for longer than 1 second to switch on the oven.



Select temperature and operating mode

1. Touch key to switch on the oven.
2. Initial operation screen appears when the oven is turned on.

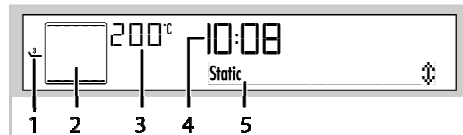



- 1 Shelf positions
- 2 Function display
- 3 Temperature/weight indicator field

4 Current time indicator field

5 Text display



This screen contains the recommended temperature under temperature/weight indicator and the active heaters and recommended tray position in the function display.

3. Touch  or  keys to select the desired operating mode (function).

After the function is selected, "Temperature", "Cook time", "Cook end time" and "Booster" (rapid heating) can be set.



4. If you want to change the temperature, touch  once to reach the temperature display.





5. Touch / until the desired temperature appears in the Temperature/Weight Indicator field. Touch  to set the temperature when the desired value appears on the display.

6. If cooking function and temperature values are suitable, touch  key to start cooking. Cooking starts and "**Cooking**" appears on the display.



 If the oven door is opened during cooking, "Door open" warning and  symbol appears on the display.

 If you touch  key briefly in this screen, "Keep pressed for 1 second" warning appears in the text field. Touch the  key for longer than 1 second to start cooking.

Switching off the electric oven

Touch  key to switch off the oven.

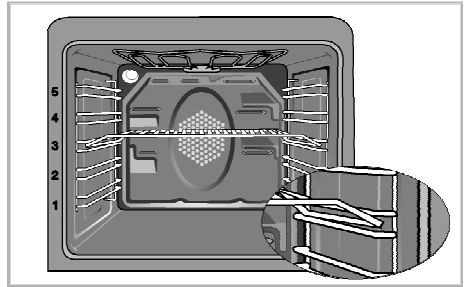



Rack positions (For models with wire grill)

It is important to place the wire grill onto the wire rack correctly. Wire grill must be inserted between the wire racks as illustrated in the figure. Do not let the wire grill stand against the rear wall of the oven. Slide your wire grill to the front section of the rack and settle it with the help of the door in order to obtain a good grill performance.

Function table

Function table indicates the functions that can be used in the oven and their respective maximum and minimum temperatures.

 Functions vary depending on the product model.

 Due to safety reasons, maximum time that can be set for "Cook time" is limited with 6 hours at all positions apart from "Warm Keeping" and "Low Temp. Cooking" functions.

 While making any adjustment, related symbols will flash on the display.

 Program will be cancelled in case of power failure. You must reprogram the oven.

 Current time cannot be set while the oven is operating in any function, or if semi-automatic or full automatic programming is made on the oven.



Even if the oven is switched off, oven lamp lights up when the oven door is opened.

Function	Recommended temperature (°C)	Temperature range (°C)
Static	200	40-280
Static + fan	175	40-280
Multi (3D)	205	40-280
Fan heat.+bottom	210	40-280
Full grill+Fan	200	40-280
Full grill	280	40-280
Low grill	280	40-280
Eco fan	180	160-220
Bottom heating	180	40-220
Warm keeping	60	40-100
Low temp. cooking	100	50-150
Defrost	-	-
Steam + Fan heating	180	150-280
Steam clean	-	-

* Functions vary depending on the product model.

Operating modes

The order of operating modes shown here may be different from the arrangement on your product.

Static

Food is heated simultaneously from the top and bottom. It is suitable for cakes, pastries, or cakes and casseroles in baking moulds. Cook with one tray.

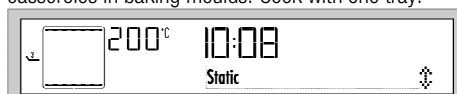

Static+fan

Hot air heated by the bottom and top heaters is evenly distributed throughout the oven rapidly by means of the fan. Cook with one tray.



Fan heating

Hot air heated by the rear heater is evenly distributed throughout the oven rapidly by means of the fan. It is suitable for cooking your meals in different rack levels and preheating is not required in most cases. Suitable for cooking with multi trays.



Multi (3-D) cooking

Top heating, bottom heating and fan assisted heating are in operation. Food is cooked evenly and quickly all around. Cook with one tray.



Fan heat.+bottom

Bottom heating and fan assisted heating (in the rear wall) are in operation. Suitable for baking pizza.



Full grill+Fan

Hot air heated by the full grill is distributed very fast in the oven by means of the fan. It is suitable for grilling large amount of meat.



- Put big or medium-sized portions in correct rack position under the grill heater for grilling.
- Set the temperature to maximum level.
- Turn the food after half of the grilling time.

Full grill

Large grill at the ceiling of the oven is in operation. It is suitable for grilling large amount of meat.



Full grill

- Put big or medium-sized portions in correct rack position under the grill heater for grilling.
- Set the temperature to maximum level.
- Turn the food after half of the grilling time.

Low Grill

Small grill at the ceiling of the oven is in operation. Suitable for grilling and gratin dishes.



- Put small or medium-sized portions in correct rack position under the grill heater for grilling.
- Set the temperature to maximum level.
- Turn the food after half of the grilling time.

Eco Fan Heating

To save power, you can use this function instead of the cooking operations that you would perform by using Fan Heating at 160-220 °C temperature range. However, the cooking time will increase a little bit. Cooking times related to this function are indicated in "Eco Fan Heating" table.



Bottom Heating

Only bottom heating is in operation. It is suitable for pizza and for subsequent browning of food from the bottom.



Warm keeping

Used for keeping food at a temperature ready for serving for a long period of time.



Low temperature cooking

Used for cooking at low temperatures in longer times (10-15 hours).



Defrost

Suitable for thawing frozen granular food slowly at room temperature and cooling down the cooked food.





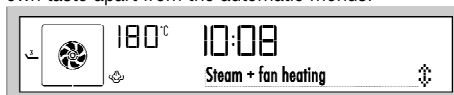

Steam Turbo

In addition to the cooking operations that you perform by using Fan Heating between 150-280°C, you will also have the option of applying steam to the dishes after the oven reaches the set temperature. But, the cooking time will increase a little bit.

This option allows you to cook dishes that fit to your own taste apart from the automatic menus.



1. Touch the key .
2. Put the dish into the oven.
3. Touch  or  to select "**Steam + Fan heating**". Then, touch the key  to start cooking. If there is no water in your system, "**Fill with 350 ml water**" appears on the display. Fill in water using the water container supplied with your oven until you hear the audio warning. See. Adding water.  symbol will be displayed when you fill in enough amount of water.



Do not use any other liquids apart from potable water in the steam system.

Steam Turbo

Close the door and “Cooking” is displayed.

“Press to spray steam” appears when the set temperature is attained. Touch the key to deliver steam into the oven for 5 minutes. You can apply steam for 3 times whenever you want during the cooking time.

 Remaining water in the system must be drained at the end of cooking. See , Draining water.

Steam cleaning

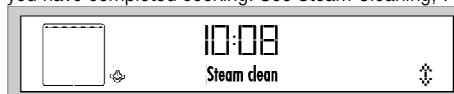

This mode is for softening dirt inside the oven after you have completed cooking. See Steam Cleaning, .



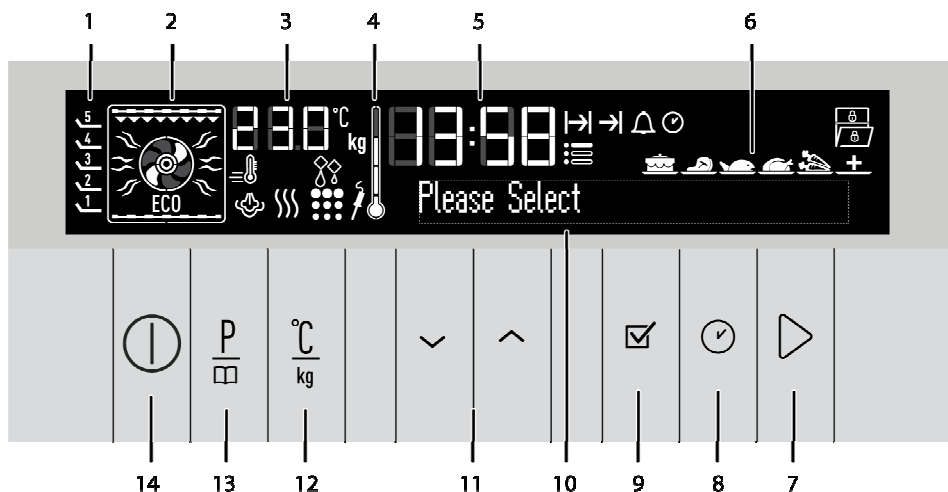

How to operate the oven control unit





- 1 Shelf positions
- 2 Function display
- 3 Temperature/weight indicator field
- 4 Oven Inner Temperature symbol
- 5 Current time indicator field
- 6 Convenience food selection display
- 7 Start/stop cooking key
- 8 Time and settings key
- 9 OK key
- 10 Text display
- 11 Up/down keys (Menu step)
- 12 Temperature/weight/booster setting key
- 13 Program selection key
- 14 ON/OFF key

 If you touch  key briefly in this screen, “Keep pressed for 1 second” warning appears in the text field. Touch the  key for longer than 1 second to switch on the oven.

2. Touch  or  keys to select the desired operating mode (function).
3. If you want to change the temperature, touch  once to reach the temperature display.



4. Touch  until the desired temperature appears in the Temperature/Weight Indicator field. Touch to set the temperature when the desired value appears on the display.
5. For cooking time, press  key for once to scroll to the “Cook time” on the text display.  symbol flashes at the same time.

Enable semi-automatic operation

In this operation mode, you may adjust the time period during which the oven will operate (cook time).

1. Touch  key to switch on the oven.

- Touch keys to set the desired cooking time and confirm the setting by touching the key. Once the Cook Time is set, will be displayed continuously.



- Put your dish into the oven and close the door.
- If cooking function, temperature and time values are suitable, touch key to start cooking. Cooking starts and **"Cooking"** appears on the display.

If you touch key briefly in this screen, "Keep pressed for 1 second" warning appears in the text field. Touch the key for longer than 1 second to start cooking.

» The oven will be heated up to the preset temperature and will maintain this temperature until the end of the cooking time you selected. The oven lamp is lit during the cooking process.

All segments of the inner oven temperature symbol (4) will turn on when the oven reaches the set temperature.

- After the cooking is completed, **"Good appetite... Press to continue"** appears on the display and alarm signal is heard.
- To stop the alarm signal, just touch any key. Oven will continue operating at the selected mode if you touch key. Alarm stops.
- Oven is switched off automatically and the current time is displayed if you do not touch the key.

Switch on fully automatic operation

In this operation mode you can adjust cooking time and end of cooking time.

- Touch key to switch on the oven.
- Touch or keys to select the desired operating mode (function).
- If you want to change the temperature, touch once to reach the temperature display.

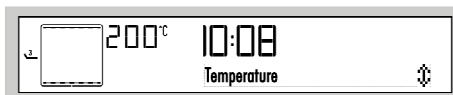

- Touch until the desired temperature appears in the Temperature/Weight Indicator field. Touch to set the temperature when the desired value appears on the display.
- For cooking time, press key for once to scroll to the "Cook time" on the text display. symbol flashes at the same time.
- Touch keys to set the desired cooking time and confirm the setting by touching the key. Once the Cook Time is set, will be displayed continuously.



- For the end of cooking time, touch with short intervals until **"Cook end time"** appears on the text display. flashes at the same time.





- Touch keys to set the desired end of cooking time and confirm the setting by touching the key. Once the Cook end time is set, will be displayed continuously.
- Put your dish into the oven and close the door.
- If cooking function, temperature, time and end of cooking time values are suitable, touch key to start cooking. **"Waiting"** appears on the display.

» Oven timer automatically calculates the startup time for cooking by deducting the cooking time from the end of cooking time you have set.
- Selected operation mode is activated when the startup time of cooking has come, **"Cooking"** appears on the display and the oven is heated up to the set temperature. It maintains this temperature until the end of the cooking time. The oven lamp is lit during the cooking process.



All segments of the inner oven temperature symbol (4) will turn on when the oven reaches the set temperature.

- After the cooking is completed, **"Good appetite... Press  to continue"** appears on the display and alarm signal is heard.
- To stop the alarm signal, just touch any key. Oven will continue operating at the selected mode if you touch  key. Alarm stops.
- Oven is switched off automatically and the current time is displayed if you do not touch the  key.



If you want to cancel the semi-automatic or automatic programming after you have set them, you need to reset the cooking time. You can also switch off the oven by touching the  key if you want.

Setting the booster (Quick heating)

Use Booster (rapid pre-heating) function to make the oven reach the desired temperature faster.





Booster can not be selected in Defrost, Slow cooking, Warm keeping and Low temperature cooking functions. Booster settings will be cancelled in case of power outage.

Select the desired cooking function and then:

- Touch the  key twice. "Booster passive" appears on the display.







- Touch the  key for once. "Booster active" warning and  symbol appear on the display. Touch  to confirm the setting.



- If cooking function and temperature values are suitable, touch  key to start cooking. Cooking starts and **"Cooking"** appears on the display.

»  symbol disappears as soon as the oven reaches the desired temperature and oven resumes operating in the function it was in before the Booster function.

- To cancel Booster function, touch the  key with short intervals until **"Booster active"** appears on the display.
- Touch the  key for once. "Booster passive" warning appears and  symbol disappears on the display. Touch  to confirm the setting.

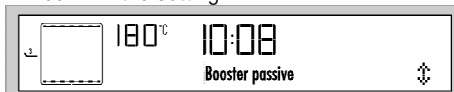





Using the keylock

You can prevent oven from being intervened with by activating the Keylock function.





Keylock can be used either when the oven is operating or not. Oven can be switched off by touching the  key even when the keylock is activated while the oven is operating.

Activating the keylock

- Touch  key with short intervals until **"Keylock passive"** appears on the display.  symbol flashes on the display.
- Touch  key for once to activate the keylock. After activating the keylock, **"Key lock active"** will appear on the display. Then, the  symbol will appear.
- Touch  to confirm the setting.





» After activating the keylock, "Keylock active" warning and  symbol will appear on the display when you press any key (except   keys).



Oven keys are not functional when the Keylock function is activated. Keylock will not be cancelled in case of power outage.

Deactivating the keylock

1. Touch  key twice to deactivate the keylock. "Key lock passive" appears on the display.
2. Touch  to confirm the setting.



» Key lock is deactivated and the  symbol on the display disappears.

Using the clock as an alarm





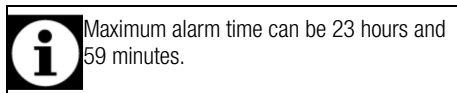

You can use the clock of the product for any warning or reminder apart from the cooking programme.

The alarm clock has no influence on the functions of the oven. It is only used as a warning. For example, this is useful when you want to turn food in the oven at a certain point of time. Alarm clock will give a signal once the time you set is over.







To set the alarm:



1. Touch  key with short intervals until  symbol appears on the display.
2. Touch  keys to set the desired time and confirm the setting by touching the  key.  symbol remains lit after setting the alarm time.
3. After the alarm time is finished,  will start flashing and an alarm signal is heard.
4. Press any key to stop the alarm.

To cancel the alarm:





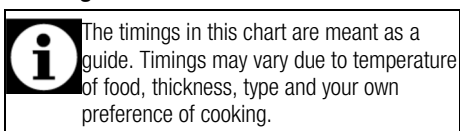



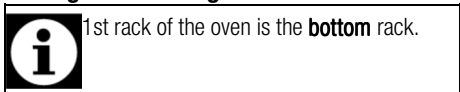







1. Touch  key with short intervals until  symbol appears on the display.
 2. Touch the  key until "00:00" appears on the display and confirm the setting by touching the  key.
- » Alarm is cancelled and  symbol disappears.

Cooking times table



Baking and roasting



Dish	Cooking level number		Rack position	Temperature (°C)	Cooking time (approx. in min.)
Cakes in tray*	One level		3	175	25 ... 30
Cakes in mould*	One level		2	180	50 ... 60
Cakes in cooking paper*	One level		3	175	25 ... 30
	2 levels		1 - 3	175	35 ... 40
	3 levels		1 - 3 - 5	180	35 ... 40
Sponge cake*	One level		3	200	8 ... 12
	2 levels		1 - 3	200	15 ... 20
	3 levels		1 - 3 - 5	200	15 ... 20
Cookies*	One level		3	175	25 ... 30
	2 levels		1 - 3	175	30 ... 40
	3 levels		1 - 3 - 5	175	35 ... 45
Dough pastry*	One level		2	200	30 ... 40
	2 levels		1 - 3	200	45 ... 55
	3 levels		1 - 3 - 5	200	45 ... 55
Rich pastry*	One level		2	200	25 ... 35
	2 levels		1 - 3	200	35 ... 45

Dish	Cooking level number		Rack position	Temperature (°C)	Cooking time (approx. in min.)
	3 levels		1 - 3 - 5	200	35 ... 45
Leaven*	One level		2	200	35 ... 45
Lasagna*	One level		2 - 3	200	30 ... 40
Pizza*	One level		2	200 ... 220	15 ... 20
	One level		3	200	10 ... 15
Beef steak (whole) / Roast	One level		3	25 min. 250/max, then 180 ... 190	100 ... 120
Leg of Lamb (casserole)	One level		3	25 min. 250/max, then 190	70 ... 90
	One level		3	25 min. 250/max, then 190	60 ... 80
Roasted chicken	One level		2	15 min. 250/max, then 180 ... 190	55 ... 65
	One level		2	15 min. 250/max, then 180 ... 190	55 ... 65
Turkey (5.5 kg)	One level		1	25 min. 250/max, then 180 ... 190	150 ... 210
	One level		1	25 min. 250/max, then 180 ... 190	150 ... 210
Fish	One level		3	200	20 ... 30
	One level		3	200	20 ... 30

When cooking with 2 trays at the same time, place the deeper tray on the upper rack and the other one on the lower rack.

* It is suggested to perform preheating for all foods.

Eco Fan Heating



Do not change the cooking temperature after cooking starts in Eco Fan Heating mode.



Do not open the door during cooking in the Eco Fan Heating mode.

Dish	Cooking level number		Rack position	Temperature (°C)	Cooking time (approx. in min.)
Cakes in cooking paper	One level		2	200	35 ... 40
Cookie	One level		2	200	30 ... 35
Dough pastry	One level		2	200	40 ... 45
Rich pastry	One level		2	200	40 ... 45

Tips for baking cake

- If the cake is too dry, increase the temperature by 10°C and decrease the cooking time.
- If the cake is wet, use less liquid or lower the temperature by 10°C.
- If the cake is too dark on top, place it on a lower rack, lower the temperature and increase the cooking time.
- If cooked well on the inside but sticky on the outside use less liquid, lower the temperature and increase the cooking time.

Tips for baking pastry

- If the pastry is too dry, increase the temperature by 10°C and decrease the cooking time. Dampen the layers of dough with a sauce composed of milk, oil, egg and yoghurt.
- If the pastry takes too long to bake, pay care that the thickness of the pastry you have prepared does not exceed the depth of the tray.
- If the upper side of the pastry gets browned, but the lower part is not cooked, make sure that the amount of sauce you have used for the pastry is not too much at the bottom of

the pastry. Try to scatter the sauce equally between the dough layers and on the top of pastry for an even browning.

i Cook the pastry in accordance with the mode and temperature given in the cooking table. If the bottom part is still not browned enough, place it on one lower rack next time.

Tips for cooking vegetables

- If the vegetable dish runs out of juice and gets too dry, cook it in a pan with a lid instead of a tray. Closed vessels will preserve the juice of the dish.
- If a vegetable dish does not get cooked, boil the vegetables beforehand or prepare them like canned food and put in the oven.
- You can cook foods made of dense dough such as buns, cake in paper, cookies or biscuits simultaneously in 1, 2 or 3 trays thanks to the homogenous heat distribution ensured by this function.
- You may cook wet dough foods such as apple pie and tart in tray simultaneously in 2 trays.
- Cooking large amount of foods containing much liquid or yeasted dough in a single tray will improve the cooking result. More homogenous cooking is obtained in large volume foods which are rising as the hot air comes from the side walls as well, which is a function not contained in conventional ovens.
- Time and energy can be saved and perfect cooking results can be obtained thanks to the multi-tray cooking feature of this function.

Ready meals functions



Selecting the ready meals functions

Ready Meals menu contains meal programmes that are prepared for you by professional cooks specially and stored in the memory of the control unit.

In this menu, temperature, rack position, weight and cooking functions are set automatically. You can change the weight and cooking time according to your meal and your taste.









To select the Ready Meals functions:

1. Touch  key to switch on the oven. Initial operation screen appears when the oven is turned on.

i If you touch  key briefly in this screen, "Keep pressed for 1 second" warning appears in the text field. Touch the  key for longer than 1 second to switch on/off the oven.



2. Touch  key to select the Ready Meals function display. In this step, "**Cakes&breads&tarts**" and the  symbol appears on the display.



3. Touch  keys to select the desired Ready Meals function main menu (Cakes&breads&tarts , Meat , Fish , Meat Poultry , Light meals , Special ).
4. Touch the  key to confirm the Main Meal menu you have selected.
5. Touch  keys to select the desired meal (Cookies, Cake, Small cake, etc).



6. Put your dish into the oven.
7. Touch  key to start cooking. "**Cooking**" appears on the display.

i If you touch  key briefly in this screen, "Keep pressed for 1 second" warning appears in the text field. Touch the  key for longer than 1 second to start cooking.

8. After the cooking is completed, "**Good appetite...**" appears on the display and alarm signal is heard.



i To stop the alarm signal, just press any key.

i "Back" appearing on the display while navigating in the meal menu allows you to return to the upper menu. Touch  key to switch to the initial function display.

Before starting to cook in the Ready Meals menu, you can set the weight depending on the meal type you have selected. To do this:

1. Touch  key after selecting the desired meal. "Weight" appears and the **kg** symbol flashes on the display.



2. Touch  keys to set the weight and confirm by touching the  key.

i Oven will change the temperature and the cooking time automatically on basis of the weight change.

i You can only change the weight for meals for which a weight is indicated.

3. Touch  key to start cooking.



Ready Meals menu:





May vary depending on the models

Cakes&bread&tarts	Meat	Fish	Meat poultry	Special meals	Special
Cookies	Meat loaf (lamb)	Fish fillet	Chicken baguette	Casserole	Fermenting
Cakes in cooking paper	Dalyan meatball	Baked anchovy	Chicken, fillet	Quiches	Home-made Yoghurt
Cheese cake	Roast beef	Haddock merlans		Macaroni cheese	Dried apple
Brownie		Salmon fillet		Lasagna	Fried chestnut
Sponge cake				Moussaka	
Apple strudel					
Apple pie					
Cinnamon rolls					



To select the steam assisted convenience food functions:



1. Touch  key to switch on the oven. Initial operation screen appears when the oven is turned on.

i If you touch  key briefly in this screen, "Keep pressed for 1 second" warning appears in the text field. Touch the  key for longer than 1 second to switch on/off the oven.

2. Touch  key with short intervals until  symbol appears on the display. In this step, "Cakes&Breads&Tarts" appears on the display.
3. Touch  keys to select the desired Ready Meals function main menu (Cakes&bread&tarts , Meat , Fish

, Meat Poultry , Light meals , Special ).

4. Touch the  key to confirm the Main Meal menu you have selected.
5. Touch  keys to select the desired meal (Cookies, Cake, Small cake, etc).
6. Put your meal into the oven.
7. Touch  key to start cooking. "Cooking" appears on the display.

i If you touch  key briefly in this screen, "Keep pressed for 1 second" warning appears in the text field. Touch the  key for longer than 1 second to start cooking.

i If the  key is not touched within 20 seconds, the oven will switch itself off.

8. **"Fill with 350 ml water"** appears on the display.

i Risk for health!
Do not use any other liquids apart from potable water in the steam system.

9. Open the door and add water through the water inlet.  symbol appears on the display together with the audio warning when filling in water.
10. Oven starts cooking and **"Cooking"** appears on the display as soon as the door is closed.
11. After the cooking is completed, **"Good appetite"** appears on the display and alarm signal is heard.
- » To stop the alarm signal, just press any key.
12. Open the oven door and take out the meal as soon as cooking completes.

Close the oven door to start the **Automatic Water Vaporization function**.

- » In this step, **"Disposing water"** and the required time appears on the display.
- » It is important for your health not to use the remaining water since the quality of the water that waits will deteriorate. Water disposal smoothens the dirt in the oven and allows it to be removed easily after cooking.
- » Wipe inside the oven with a cloth after disposing the water.

Using the water container:

Water container consists of 2 pieces. Upper piece removes the lime in the water. Assemble the lower and upper parts of the container as illustrated.

Do not fill more than 150 cc, otherwise the water is not purified.

Remove the upper part and pour the water into the oven with the lower part.

i Remove the lime in the water container by applying the following procedure once in every 4 usages. Dissolve 2 teaspoon of salt in a glass and pour into the water container. And then, wash the lower container.

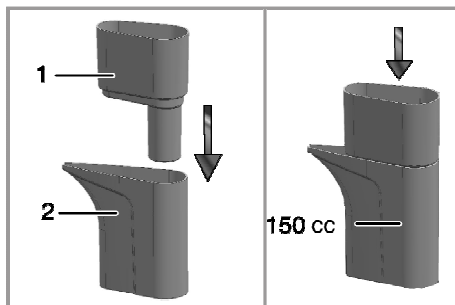

- 1 Upper part
2 Lower part

Adding water:

1. Pull the pitcher illustrated in the figure (1).
2. Pour water into the container until you hear the signal sound. Observe the amount of water from the water level indicator (2).

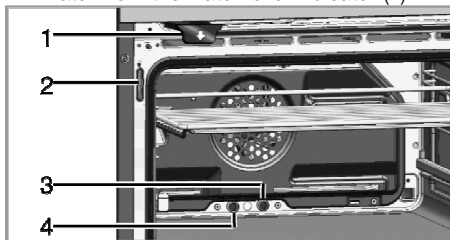

- 1 Pitcher
2 Water indicator
3 Vapour exit pipe
4 Drainage pipe for excessive water

i The system waits at least 10 minutes for you to add water. If you do not add water in 10 minutes, oven switches off.

i To clean the pitcher, remove it from the oven and wash with water only.

i Water level in the tank should be checked through the water indicator while adding water. If the water level exceeds the tank full level, excessive water will run into the oven. Excessive water that run into the oven can affect cooking in steam assisted automatic cooking programmes and cause condensation on the door. In order to avoid this, remove the excessive water that has run into the oven before cooking starts.

i If the oven is switched off before the cooking is completed and no cooking function is selected within 2 minutes, **"Please take the meal. Water will evaporize."** message will appear on the Text display soon as the oven is switched on with **ⓘ** key. Water disposal starts automatically after around 1 minute.

CAUTION
 Keep the door closed during water vaporization.

Steam assisted convenience food menu:
 May vary depending on the models

Cakes&Breads&Tarts	Meat poultry	Light meals	Fish	Meat
Pizza, fresh thinbase	Chicken < 1600 gr	Fresh vegetable, graten	Trout casserole	Roast lamb
Pizza, fresh thickbase	Chicken > 1600 gr	Frozen vegetable, graten		Leg of lamb
Dough pastry	Turkey, thigh	Jacket potatoes		Veal pot roast
Vol au vent	Duck, whole			Tandoori
Fruit cake				
Short bread				
Rich pastry				
Bagel				
Loaf bread (yeasted)				
Sandwich bread				
Baguette				
Bread rolls, frozen				

Settings menu

Brightness setting

Brightness can only be set when the oven is switched off.

1. Touch **ⓘ** key with short intervals until "Brightness" appears on the display. **≡** symbol flashes on the display.



2. There are 5 brightness levels, namely 1, 2, 3,4 and 4. Touch **↶** **↷** keys to select the desired level.
3. Touch **✓** to confirm the setting.

i Brightness level decreases to save power when the oven is switched off. It restores to the set level again when the oven is switched on.

» It returns to the stand-by display. Only the current time appears on the display.

Voice Level setting

Voice level can only be set when the oven is switched off.

1. Touch **ⓘ** key with short intervals until "Voice Level" appears on the display. **≡** symbol flashes on the display.





- There are 2 voice levels, namely 1 and 2. Touch  keys to select the desired level.



- Touch  to confirm the setting.
» It returns to the stand-by display. Only the current time appears on the display.

Language setting

Language can only be set when the oven is switched off.



- Touch  key with short intervals until "Language" appears on the display.  symbol flashes on the display.







- Touch  keys to select the desired language.
- Touch  to confirm the setting.
» It returns to the stand-by display. Only the current time appears on the display.

Current time setting

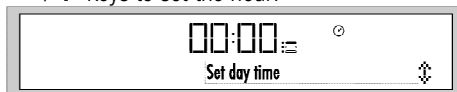
Current time can only be set when the oven is switched off. If you want to change the time that was set during initial setup:

- Touch  key with short intervals until "Day time" appears on the display. Hour field and  symbol flash on the display. Touch  keys to set the hour.



- Touch  to confirm the hour.
- Minute field and  symbol flash on the display. Touch  keys to set the minute. Touch  to confirm the minute.
» It returns to the stand-by display. Only the current time appears on the display.



How to operate the grill



 Before you can use the oven, the time must be set. If the time is not set, oven will not operate.







WARNING

Close oven door during grilling.
Hot surfaces may cause burns!

Switching on the grill

- Touch  key to switch on the oven.
- Touch  to select the desired grill function.

After the function is selected, "Temperature", "Cook time", "Cook end time" and "Booster" (rapid heating) can be set.

- If you want to change the temperature, touch  once to reach the temperature display.
- Touch  until the desired temperature appears in the Temperature/Weight Indicator field. Touch  to set the temperature when the desired value appears on the display.
- If cooking function, temperature and time values are suitable, touch  key to start cooking. Cooking starts and "**Cooking**" appears on the display.

Switching off the grill

- Touch  key to switch off the oven.

Rack positions

Grill performance will decrease if the wire grill stands against rear part of the oven. Slide your wire grill to the front section of the rack and settle it with the help of the door in order to obtain the best grill performance.

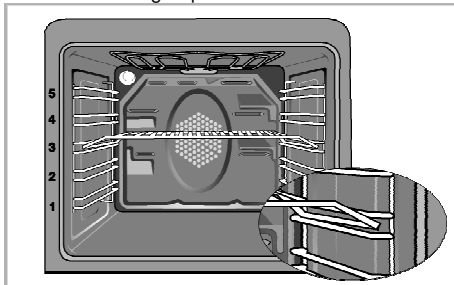

Foods that are not suitable for grilling carry the risk of fire. Only grill food which is suitable for intensive grilling heat.

Do not place the food too far in the back of the grill. This is the hottest area and fatty food may catch fire.

Cooking times table for grilling

Grilling with electric grill

Food	Insertion level	Grilling time (approx.)
Fish	4...5	20...25 min. #
Sliced chicken	4...5	25...35 min.
Lamb chops	4...5	20...25 min.
Roast beef	4...5	25...30 min. #
Veal chops	4...5	25...30 min. #
Toast bread	4	1...2 min.

depending on thickness

6 Maintenance and care

General information

Service life of the product will extend and the possibility of problems will decrease if the product is cleaned at regular intervals.



DANGER:

Disconnect the product from mains supply before starting maintenance and cleaning works.
There is the risk of electric shock!



DANGER:

Allow the product to cool down before you clean it.
Hot surfaces may cause burns!

- Clean the product thoroughly after each use. In this way it will be possible to remove cooking residues more easily, thus avoiding these from burning the next time the appliance is used.
- No special cleaning agents are required for cleaning the product. Use warm water with washing liquid, a soft cloth or sponge to clean the product and wipe it with a dry cloth.
- Always ensure any excess liquid is thoroughly wiped off after cleaning and any spillage is immediately wiped dry.
- Do not use cleaning agents that contain acid or chloride to clean the stainless or inox surfaces and the handle. Use a soft cloth with a liquid detergent (not abrasive) to wipe those parts clean, paying attention to sweep in one direction.



The surface might get damaged by some detergents or cleaning materials.
Do not use aggressive detergents, cleaning powders/creams or any sharp objects during cleaning.
Do not use harsh abrasive cleaners or sharp metal scrapers to clean the oven door glass since they can scratch the surface, which may result in shattering of the glass.



Do not use steam cleaners to clean the appliance as this may cause an electric shock.

Cleaning the pitcher

Pitcher stops at a certain point when you pull it towards yourself.
When you continue pulling, it arrives at the second stop point and stops again.
If you continue pulling after this point it will get out of its place.

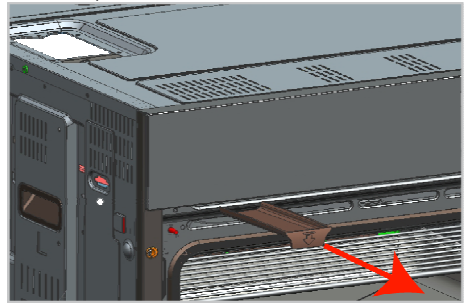

You can clean the pitcher under tap water after removing it.



Do not use chemical materials when cleaning the pitcher. Use only water.

Cleaning the control panel

Clean the control panel and control knobs with a damp cloth and wipe them dry.



Do not remove the control buttons/knobs to clean the control panel.
Control panel may get damaged!

Cleaning the oven

To clean the side wall

1. Remove pin **(1)** of the side rack by pulling it in the direction of arrow with the side wall it is mounted.

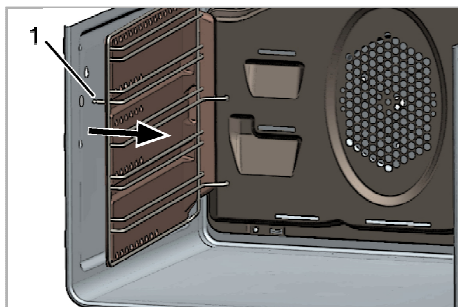

2. Remove the side rack and side wall completely by pulling it towards you.
3. Remove the side rack from the holes (2) on the oven wall by pulling.
4. To clean the side rack and side wall, use warm water with washing liquid, a soft cloth or sponge to clean the product and wipe it with a dry cloth.
5. Place side rack by pulling to holes (2) on the back of side wall.

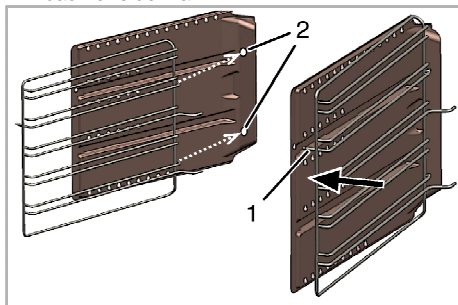

6. Lock side rack to side wall by pulling pin (1) of side rack in the direction of arrow.
7. Place side rack and side wall assembly to its place by pulling pins (3) to holes on the back wall as shown in figure.

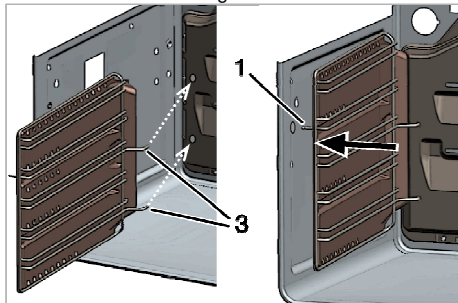

8. Place pin (1) at side rack to its place as shown in figure.

i Be sure that side rack and side wall has been placed properly.

Steam Cleaning

It ensures easy cleaning because the dirt (having waited not for too long) is softened with water drops condensing inside the oven after giving steam for a certain time.

1. Press **⏻** key to switch on the oven.
2. Make sure you have removed the food.
3. Press **⬆** or **⬇** key to select **"Steam cleaning"** mode.

4. Press **▶** key to start cleaning.

If there is no water in the system, **"Fill with 350 ml water"** appears on the displayed.

5. Fill in water using the water container supplied with your oven until you hear the audio warning.
6. **⚠** warning will be displayed when you fill in enough amount of water.

i Risk for health!
Do not use any other liquids apart from potable water in the steam system.

» If the temperature inside the oven is below 100 C when the door is closed, cleaning starts without delay. If inner temperature is not below 100 C with the water filled and door closed, **"Cooling"** message appears on the screen.

» When inner temperature falls below 100 C, cleaning starts automatically.

7. When cleaning starts, **"Cleaning"** message is displayed.

» Steam is delivered into the oven until the water of the system runs out.

i Steaming takes approximately 35 minutes with the completely full container. This time will be shorter for less water.

8. When the water runs out, **"Wipe the surfaces"** is displayed.

9. Open the door and wipe the inner surfaces of the oven with a damp sponge or cloth.

When the cleaning is over (generally water runs out), remaining water should be drained in any case. See Cooking Guide Functions, , Draining water.

Clean oven door

To clean the oven door, use warm water with washing liquid, a soft cloth or sponge to clean the product and wipe it with a dry cloth.

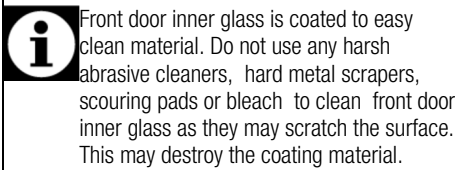
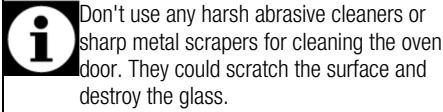

Removing the oven door

1. Open the front door (1).
2. Open the clips at the hinge housing (2) on the right and left hand sides of the front door by pressing them down as illustrated in the figure.

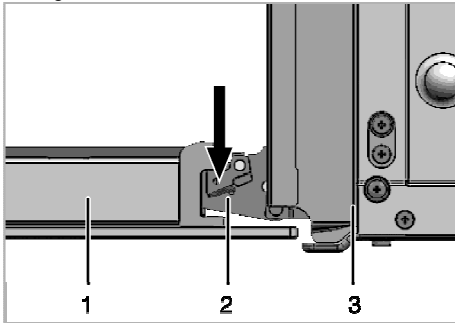

- 1 Front door
- 2 Hinge
- 3 Oven

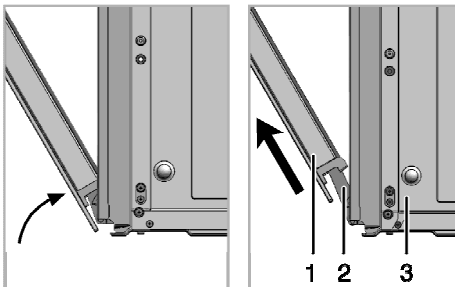

3. Move the front door to half-way.

4. Remove the front door by pulling it upwards to release it from the right and left hinges.

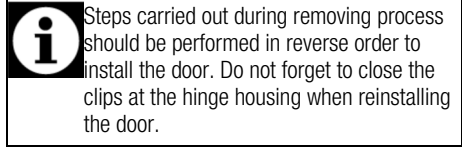

Removing the door inner glass

The inner glass panel of the oven door can be removed for cleaning.

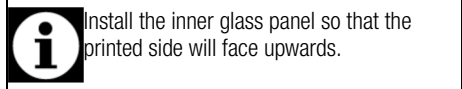

Open the oven door.

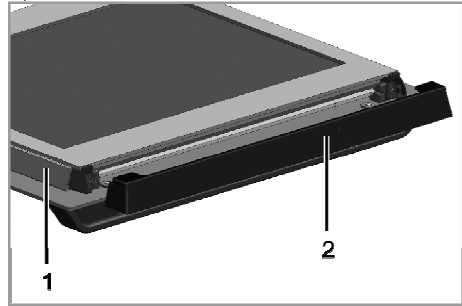

- 1 Frame
- 2 Plastic part

Pull towards yourself and remove the plastic part installed to upper section of the front door.

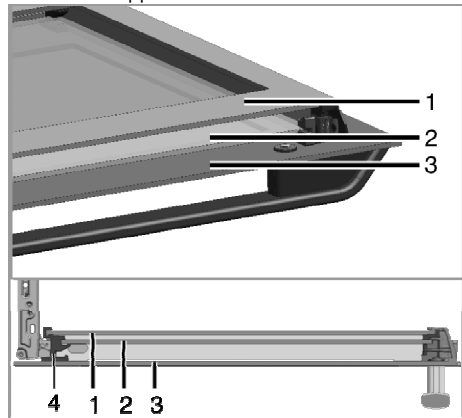

- 1 Innermost glass panel
- 2 Inner glass panel
- 3 Outer glass panel

4 Plastic glass panel slot-Lower

As illustrated in figure, raise the innermost glass panel (1) slightly in direction **A** and pull it out in direction **B**.

Repeat the same procedure to remove the inner glass panel (2).

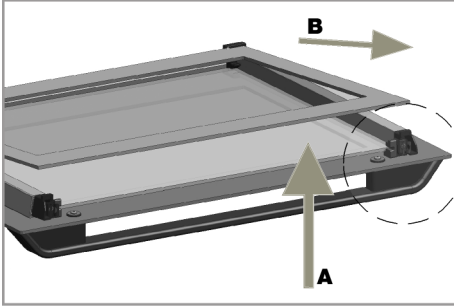

The first step to regroup the door is reinstalling inner glass panel (2).

As illustrated in figure, place the chamfered corner of the glass panel so that it will rest in the chamfered corner of the plastic slot.

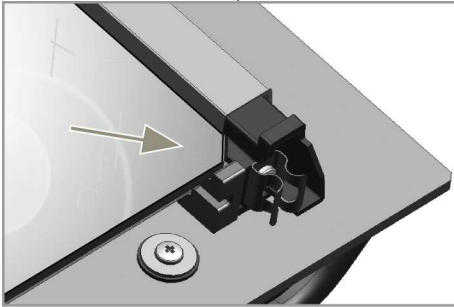

Inner glass panel (2) must be installed into the plastic slot close the innermost glass panel (1).

When installing the innermost glass panel (1), make sure that the printed side of the panel faces towards the inner glass panel.

It is important to seat lower corner of inner glass panel into the lower plastic slot.

Push the plastic part towards the frame until you hear a "click".

Replacing the oven lamp



DANGER:

Before replacing the oven lamp, make sure that the product is disconnected from mains and cooled down in order to avoid the risk of an electrical shock. Hot surfaces may cause burns!



The oven lamp is a special electric light bulb that can resist up to 300 °C. See *Technical specifications, page 10* for details. Oven lamps can be obtained from Authorised Service Agents.



Position of lamp might vary from the figure.

If your oven is equipped with a round lamp:

1. Disconnect the product from mains.
2. Turn the glass cover counter clockwise to remove it.

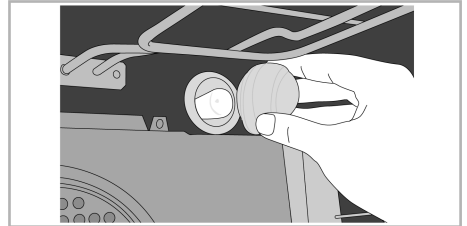

3. Pull out the oven lamp from its socket and replace it with the new one.
4. Install the glass cover.

7 Troubleshooting

Oven emits steam when it is in use.

- It is normal that steam escapes during operation. >>> *This is not a fault.*

Product emits metal noises while heating and cooling.

- When the metal parts are heated, they may expand and cause noise. >>> *This is not a fault.*

Product does not operate.

- The mains fuse is defective or has tripped. >>> *Check fuses in the fuse box. If necessary, replace or reset them.*
- Product is not plugged into the (grounded) socket. >>> *Check the plug connection.*
- Buttons/knobs/keys on the control panel do not function. >>> *Keylock may be enabled. Please disable it. (See.)*

Oven light does not work.

- Oven lamp is defective. >>> *Replace oven lamp.*
- Power is cut. >>> *Check if there is power. Check the fuses in the fuse box. If necessary, replace or reset the fuses.*

Oven does not heat.

- Function and/or Temperature are not set. >>> *Set the function and the temperature with the Function and/or Temperature knob/key.*
- Power is cut. >>> *Check if there is power. Check the fuses in the fuse box. If necessary, replace or reset the fuses.*



Consult the Authorised Service Agent or the dealer where you have purchased the product if you can not remedy the trouble although you have implemented the instructions in this section. Never attempt to repair a defective product yourself.

Filename: 285442412.doc
Directory: \\ar.arcelik\arcdfs\bol\bol-users\AR720007
Template: D:\Documents and Settings\ar720007\Application
Data\Microsoft\Templates\Normal.dotm
Title:
Subject:
Author: Arcelik BT
Keywords:
Comments:
Creation Date: 16.05.2013 09:07:00
Change Number: 3
Last Saved On: 16.05.2013 09:07:00
Last Saved By: Arcelik BT
Total Editing Time: 10 Minutes
Last Printed On: 16.05.2013 09:26:00
As of Last Complete Printing
Number of Pages: 40 (approx.)
Number of Words: 13.543 (approx.)
Number of Characters: 77.198 (approx.)